

# Sterling® FIXED AND RETRACTABLE KNIVES

## FIXED KNIVES



### NIGHTHAWK - 3031

Tough and wear resistant premium D2 steel blade. Curved drop point smooth blade. Premium stone washed black oxide finish. Flip out design with bearing system and blade lock. Handy belt clip. Suitable for: Trades, sport, hunting, fishing, camping and much more.



### SHARK - 105

Ideal for heavy duty uses. Quick release "dial" for fast, easy blade changes. Ergonomic shape fits securely and comfortably in the hand. Cast aluminum construction is strong but very light. Supplied with plastic belt holster. Clamps blade securely - no movement. Single notch to adjust blade length. Ideal for flooring, plasterboard, mining, rubber belting and other industries.



### ULTRA-LAP - 102

Large overlaps to prevent injuries. The most popular carpet laying knife. Traditional style knife with knurled sides for grip. Double notches for reduced wear. Strong and lightweight.

**XL PREMIUM GOLD T1N COATED**  
**8X LONGER LASTING**



**XL PREMIUM SILVER**  
**4X LONGER LASTING**

### XL PREMIUM GOLD AND SILVER BLADES

- Precision ground and sharpened to a razor edge
- Maximum sharpness and durability
- Enhanced polished finish for rust resistance
- 1.25% high carbon steel for excellent durability



### 921 HEAVY DUTY UTILITY KNIFE BLADES

Australia's No.1 Blade! Premium English quality available in 10 and 100 packs and a safety dispenser of 100.

921 - HEAVY DUTY



## RETRACTABLE KNIVES



### AUTOLOADING - 112

Front loading blades. Safety button allows blades to be removed or turned without opening knife body. 5 blade magazine automatically re-loads new blades. Unique shape for superior grip and control. Heavy duty all metal construction with smooth reliable mechanism. Auto blade loading reduces accidents. All metal mechanisms - metal springs and slides.



### SPORT PRO II - 3039

Multi-use knife with both quick-change utility blade and fold out sport and rescue blade. Secure rubber grip and compact folding design for ease of use and comfortability. Safety folding latch allows both blades to be safely folded for carrying. Handy belt clip for portability.



### ULTRA-GRIP - 115

Ergonomic shape fits all size hands. The most popular Sterling retractable knife. Ribbed body for improved hand grip with gloves. Die cast zinc construction for longer life. Large overlap above and below blade to prevent injuries. Hi-vis safety yellow stands out for easy locating.



### STEALTH KNIFE - 3038 AUTOLOADING POCKET KNIFE

Automatic blade loading. Highest quality blades. Easy blade change function allows blade to be removed, turned or reloaded without opening the knife. Comfortable shaped grip. 5 blade storage compartment.

# Sterling® SNAP CUTTERS AND BLADES

## SNAP CUTTERS



Sterling®

### ALL-METAL - 360

Slim stainless steel body for ultimate durability. Auto-lock mechanism prevents blade slipping. Handy pocket clip to keep it in your shirt pocket. Supplied with 3 blades.



Sterling®

### AUTO-LOCK - 330

Stainless steel sleeve for long life. Refined auto-lock mechanism prevents blade slipping. Handy pocket clip to keep it in your shirt pocket. Original style is a favourite with industry. Replacement blades in knife body. Supplied with 3 blades. Metal safety blade snapper for controlled snapping. Brilliant for graphic arts and tint film.



Sterling®

### ZEBRA - 580

Aluminium casing is strong but lightweight. Rubber hand grip is comfortable and secure. Strong long lasting stainless steel blade slider. Screw-lock blade locking for secure, positive holding power.



Sterling®

### SCREW-LOCK - 550

The popular traditional screw-lock cutter. Ergonomic body fits all hands comfortably. Refined mechanism for ease of use. Supplied with snapper for safe removal of blade segments. Supplied with 3 blades.



Sterling®

### SCREW-LOCK EXTRA LONG - 565

Screw-lock mechanism. Ribbed for controlled gripping. Ergonomic body fits all hands comfortably. Super long reach.



**Sterling**

**EXTRA HEAVY DUTY - 700**

The most popular 25mm extra heavy duty cutter. Screw-lock provides peace of mind when tightening blade. Rubber grip on rear reduces hand slipping when applying pressure. Extra-thick stainless steel sleeve for longer life. Supplied with 2 blades.



**Sterling**

**COMMANDER - 760**

Extra heavy duty 25mm cutter with strong auto-lock system for fast, safe blade adjustments. All metal construction is durable and strong. Ribbing on body to provide secure grip. Metal clip and blade snapper on back of cutter. Wider and thicker 0.7mm blade reduces flex in heavy cutting.

Visit [sheffield.com.au](http://sheffield.com.au) to view the full knife and blade range



**201 - 18MM SEGMENTED: XL SILVER**  
18mm blade

**201 - 18MM SEGMENTED: XL GOLD**  
18mm blade

**201 - 18MM SEGMENTED**  
18mm blade

**203 - NON-SEGMENTED**  
18mm blade

**200 - SEGMENTED**  
9mm blade

**202 - NON-SEGMENTED**  
9mm blade

Premium quality snap off and non-segmented blades available for all applications in 9mm, 18mm and 25mm widths. Pack sizes from 10 to 50 blades. Blades made in Europe, England and USA.

## SAFETY KNIVES



*Sterling*®

### SAFETY THUMLOCK - 115-1YR

Automatic blade retracting system reduces accidents. Thumlock screw for easy blade changes without tools. Die cast all metal construction for maximum strength. Ribbed body with Suregrip design prevents slipping, designed for gloved hands. Supplied with safety tip blade.



*Sterling*®

### DOUBLE-PLUS - 417

Automatic self retracting blade system reduces injuries. Blade still retracts if contact is lost even when slider is still pushed forwards. Rounded thumb slider can be used from both sides or the top. Rubberised grip avoids slipping. Easy blade changes with no tools. Safety tip blade protects carton contents.



*Sterling*®

### LONGREACH LEFTHANDED - 416-L

Left handed use. Longest reach of any knife with automatic blade retracting system. Rubbergrip on body is comfortable and prevents slipping. Symmetrical design allows blade to be inserted upside down for left hand users.



*Sterling*®

### SIDE-SLIDE - 412

Automatic blade retracting system prevents injuries. Symmetrical design allows blade to be inserted upside down for left handed users.



*Sterling*®

### MICA - 100R

Automatic blade retracting system prevents injury. Light weight design with 4 edged blade. Limited depth of cut with rounded edge blade protects carton contents. Suitable for cutting seat belts, film, shrink wrap, bubble wrap and plastic strapping etc.

## SAFETY TOOLS



*Sterling*

### KLEVER TYPE SAFE EDGE CUTTER - 326-2

Enclosed blade safety cutter. Tips can be used as a tape cutter. Unique shape prevents damage to carton contents. Light, safe and easy to use and disposable

*Sterling*

### TUSK II - 441

Super sharp circular blade cuts most packaging materials. Big grip and sturdy body for demanding applications. Rubber grip handle is comfortable and prevents slipping. Tape slitter on back of cutter allows safe opening of cartons. Easy blade changes without tools.



*Sterling*

### BLADE DISPOSAL CASE - BLR

Safe disposal of used blades. Suits all type of blades and blade segments. Compact design clips to your belt.



Over 45 different safety knives and cutters are available in the Sterling Safety Range

The Sterling range includes a wide variety of premium quality blades to suit all safety knife and cutter applications.

961 - HOOKED



451-040 - ROUND MICA



RB-03 - 28MM ROTARY



928 - BLUNT POINT



416B - LONG REACH



# Sterling® BLACK PANTHER RANGE

## ULTIMAX PRO BLACK PANTHER GEN II SNIPS

**HRC53**  
ROCKWELL  
HARDNESS

**NEW AND  
IMPROVED**



**Sterling®**

### BLACK PANTHER GEN II SNIPS - 29-721

Comfort grip handles made from impact and solvent resistant TPR material. Anti-slip ridges for extra grip. Smooth, resistance free friction washer and stainless steel bolt. Stainless steel serrated edge blades for increased cutting capacity. Upgraded locking clasp with comfort grip.

Ideal knife replacement tool featuring quality 420J2 stainless steel and carbon construction, giving them a constant sharp edge and corrosion resistance in industrial environments.

Ideal for: Cable, aluminium, sheet metal, carpet, leather, rubber, gardening, food prep, camping and more



**UNIQUE**  
TRY ME PACKAGING!

Black Panther Gen II 185mm High Tensile, Rounded Tip and 200mm Long Cut also available.



Sterling's Black Panther snips are produced to the highest levels of engineering with a total commitment to develop the most durable and refined industrial snip on the market.

- Fully adjustable pivot
- Simple safety latch
- Premium Japanese stainless steel serrated blades for smooth trouble free cutting
- Ideal for all industrial applications including wire netting, light gauge aluminium, carpet, leather, Kevlar®, and many other items



## ULTIMAX BLACK PANTHER SNIPS



**Sterling**<sup>®</sup>

### BLACK PANTHER SNIPS

185mm (7") industrial snips. Ergonomically designed acid and solvent resistant comfort grip handles. Premium stainless steel serrated edge blades - smooth trouble free cutting. Ideal for multiple applications from thin wire to Kevlar<sup>®</sup>. Ideal knife replacement tool. Also available in: 185mm High Tensile and 200mm Long Cut.

### SAFETY ROUNDED TIP

Also Available  
29-704



### LEATHER SNIP HOLSTER

Now Available  
STC75



## BLACK PANTHER SCISSORS

**Sterling**<sup>®</sup>

### BLACK PANTHER MULTI-PURPOSE

Multi-purpose use in food, garden and industry. High quality Japanese steel blades, extremely sharp and durable Serrated blades with anti-slip function. Featuring: Tape cutter on closed blade edge, saw blade and ambidextrous handles.



**Sterling**<sup>®</sup>

### BLACK PANTHER KNIFE EDGE TAILORING

Premium quality tailoring shears. Ambidextrous comfort grip handles. Supremely sharp smooth knife edge stainless steel blades. Ideal for tailoring, upholstery and industrial applications. Available in 210mm (8") - 300mm (12") sizes.



Visit [sheffield.com.au](http://sheffield.com.au) to view the full scissor and shear ranges





**Sterling®**

### AVIATION AND OFFSET TIN SNIPS

Drop forged molybdenum alloy blades induction hardened for long life. Cuts up to 1.5mm cold rolled steel or 1.0mm stainless steel. Hi-tensile pivot bolt for maximum durability. Squeeze quick-release handle catch. TPR rubber grip handles for extra comfort. Comes with a plastic belt holster. Aviation and offset tin snips come in right and left cut. Long cut and straight cut aviation tin snips available.

**Sterling®**

### COMFORT GRIP LOCKING PLIERS

Constructed from chrome vanadium steel for maximum toughness. Thermoplastic rubber handles ensures slip resistance and extra comfort. Available in 250mm straight and 250mm curved jaw.



**Sterling®**

### ADJUSTABLE PLIERS

Comfortable rubber grip. Ratchet automatically adjusts to required size. One hand operation. Jaw design reduces slipping and effort. Anti-pinch guard. Chrome vanadium with black phosphate finish. Available in 175mm (7"), 250mm (10") and 300mm (12").



**Sterling®**

### WIDE JAW ADJUSTABLE WRENCHES

Thin jaws allow access to confined spaces. Jaw angle of 15° for a secure grip on the nut. Comfort grip, anti-slip handle. Available in 150mm (6") 200mm (8"), 250mm (10") 300mm (12").





**T-REX SAW - 50-770**

**Sterling®**

550mm (22") 8TPI Handsaw with triple ground shark point teeth for fast cuts even in hardwood. Hardened teeth are durable and will cut a wide range of materials including timber, laminated boards, plastic pipe, plasterboard, cornices, etc. Rubber grip handle is comfortable, secure, and has 90° and 45° angles for accurate marking out.



**Sterling®**

**T-REX 6" DRYWALL SAW - 50-660**

Hardened teeth keyhole saw. Triple edge grinding cuts forward and backwards. Ergonomic rubber grip handle. Sharpened and hardened triple point tip for easy job starting.



Quick release handle for fast and easy blade change.



Unique high tension blade clamping thanks to the combination of the lever blade change system and tensioning screw.

**Sterling®**

**RHINO GRIP BI-METAL HACKSAW FRAME - HF-506**

Ergonomic rubber grip for comfortable extended cutting and a unique high tension hold system. Solid steel core frame covered in moulded ABS plastic.



**Sterling®**

**STERLING BI-METAL**

Bi-Metal flexible blade 12" / 300mm. Virtually unbreakable. Industrial quality. Available in 18, 24 and 32 TPI.



## STRIKER - HX-520

*Sterling®*

Drop forged for extra strength. Cushion grip rubber handle. Excellently balanced for superior control.



*Sterling®*

## ALUMINIUM CHALK LINE - CLS-A

Rewinds 5x faster than standard chalk lines. Made from a durable die cast aluminium housing for strength and durability. Spool release button for rapid release of chalk line. Includes 113g bottle of blue chalk.



*Sterling®*

## ABS CHALK LINE - CLS-P

Rewinds 3x faster than standard chalk lines. Made from durable ABS housing with an ergonomic rubber grip for ease of use. Spool release button for rapid release of chalk line. Includes 113g bottle of blue chalk.

*Sterling®*

## CHALK REFILLS

Perfect for use in all chalk line reels. Made to lay down a hard clean line that won't blow away

170/226g available in colours: Blue, Red, Black, Fluro orange, Fluro green, Violet and White

2.26kg available in colours: Blue and Red



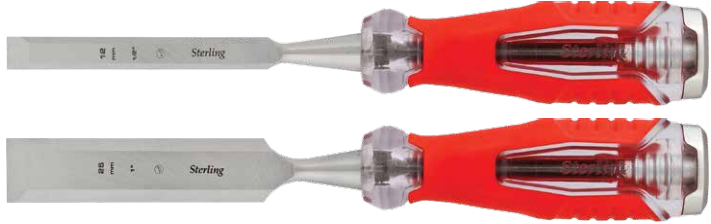

**WOOD CHISELS**

Full hardened blade for professional use and long life. Premium quality acetate handle with ergonomic over molded grip for comfort. Extra large striking cap for repetitive use at any angle. Available in sizes : 6mm, 10mm, 12mm, 16mm, 19mm, 22mm, 25mm, 32mm, 38mm and 50mm. 3 and 5 Piece sets also available.



**MAGNETIC TORPEDO LEVEL - TL230**

230mm. Die cast aluminum body for durability with 3 unbreakable acrylic shockproof vials. Two rare earth magnets providing ultimate grip on metal surfaces. Push release 180° rotating vial to duplicate angles, slopes and pitch.



**SPRING CLAMP**

Cushion tips for added protection on soft materials. Strong and durable steel tension spring for long life. Available in sizes: 110mm, 150mm and 175mm



**BAR CLAMP**

Cushion tips grip firmly and allow added protection on soft materials. Ergonomic nylon handles with ribbed design for extra grip. Induction hardened steel rail ensures longer life. Quick conversion form clamp to spreader. Available in sizes: 150mm, 300mm, 450mm and 600mm



**ALL NEW DESIGN**

# Sterling® DEBURRING TOOLS



**COMPOSITE ACETAL AND RUBBER BODY**



**COMFORT GRIP WITH RUBBER NOSE AREA**



**BALL END PROVIDES COMFORT, CONTROL AND SECURITY**



*Sterling®*

**C TYPE COMFORT GRIP DEBURRER - DT-MK**

Secure quick-release blade holding system. Blade storage in rear. Supplied with C-10, C-20 and C-30 blades.



*Sterling®*

**DETAIL COMBO SCRAPER COMFORT GRIP - SCR-6-MK**

Double ended scraper blade - triangular and internal. Supplied with SCR-6 blade.



*Sterling®*

**SINGLE AND DOUBLE EDGE DEBURRER - V-2-MK**

Double ended - double edge up to 4mm or single edge up to 6.5mm, supplied with V2 blade.



*Sterling®*

**SHEET / RIB DEBURRER - VDT-MK**

For deburring both sides of sheet or narrow material. Supplied with V-4 blade and telescopic handle.

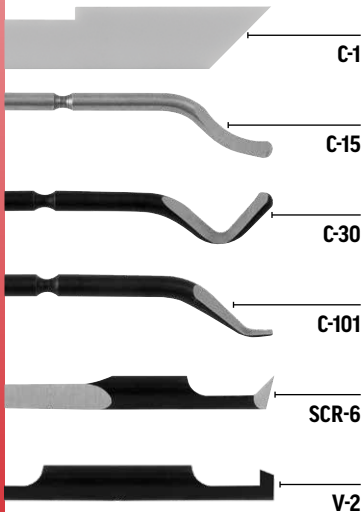

**14 PIECE DEBURRING SET**

Contains: Comfort grip handle, blade holders and assorted blades, combo scraper and countersink.

**24 PIECE DEBURRING SET**

Contains: 3 comfort grip handles, blade holders and assorted blades, scrapers and countersink.

Full range of deburring tools, blades and handles available at [sheffield.com.au](http://sheffield.com.au)

## COMBINATION SQUARES AND RULERS

*Sterling*

### COMBINATION SQUARES

Multi purpose gauge. Strong and accurate. Stainless steel blade with etched markings for durability. Machined faces and locking spring ensure accuracy and precision adjustment. Inbuilt scriber.

- Standard combination square: aluminium headstock
- Heavy duty combination square: cast iron headstock
- Available in metric and metric / imperial



*Sterling*

### FOLDING RULE

Made from white engineered plastic. Virtually unbreakable. Graduations on both sides in mm, 10mm increments on the top edge. Folds out to 1000mm.

Smooth, heavy-duty hinge. Markings etched for long life. Bevelled edge for easy marking out. 10mm thick when folded.

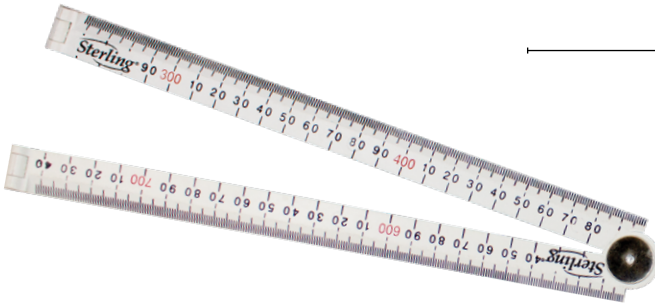

*Sterling*

### SLIDING BEVEL

300mm heavy duty sliding bevel. High quality, thick stainless steel blade. Strong and sturdy aluminium billet handle. Free and easy movement with positive lock. Square tolerance 0.1/100mm. Blade thickness 1.8mm.



*Sterling*

### STAINLESS STEEL RULERS

Hardened stainless steel rules. ISO9001 certified manufacturer assures accuracy. All markings are etched into the stainless steel for durability. Metric only rules have conversion chart on back.

- Metric / imperial markings and metric only markings available
- Available in 150, 300, 450, 600, 1000, 1500 and 2000mm



## TAPE MEASURES

**Sterling®**

### STERLING E - 889

Rubber back case. Metric or metric/imperial markings. 3 rivet end hook. The most consistently accurate value tape measure range.

- Available in 8m metric and 8m/27ft metric/imperial



**Sterling®**

### V-FLURO

Compact design for easier handling. Hi-vis colours to locate quicker in a toolbox. Clear graduated mm markings.

- Available in green, pink, orange and yellow
- Available in 8m metric



**NEW 120M LENGTH**



**Sterling®**

### TLR PROFESSIONAL

10mm abrasion resistant nylon coated steel blade. Rubber grip impact resistant case. Belt clip on back. Claw and loop end hook for any job. Easy winder in side for fast retraction.

- Available in 20m metric and 30m metric and metric / imperial



**Sterling®**

### OPEN REEL FIBREGLASS TAPE - 120M

Strong compact ABS casing with rubber grip handle. 15mm extra wide reinforced fibreglass tape. 3x speed winder mechanism saves rewinding time. Metric markings both sides of tape. Strong reinforced end hook and true zero claw.



**Sterling®**

### XBA FAT BLADE

20mm extra wide reinforced fibreglass tape. Geared 3x speed winder mechanism saves rewinding time. Strong reinforced end hook with magnetic loop and true zero claw. Super strong reinforced hook connection to tape ideal for mining.

- Available in 30m and 50m

**TAPE MEASURES**



Magnetic

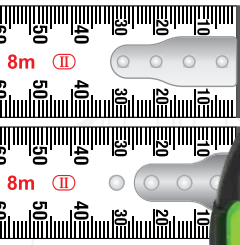

**WIDE  
LAYERED  
EASYREAD  
SUPERBLADE**



**ALSO AVAILABLE:** 10m Easyread



**STANDARD:** 8m



**ULTIMAX PRO**

Premium 8m tape measure. Wide blade with reinforced 4 rivet dual hook with magnet. Layered SuperBlade for maximum durability with double sided blade printing and extended standout. Superior internal mechanism providing smooth operation. High impact resistant ABS casting with non-slip grip.

- Available in 8m metric, 8m metric Easyread and 10m Easyread



**EASYREAD:** 8m



**ALSO AVAILABLE:** 10m & 5m Easyread



**ULTIMAX**

8m tape measure. High impact resistant ABS casting with non-slip grip. 25mm blade with reinforced 4 rivet dual hook. Layered nylon blade for maximum durability with double sided blade printing with super standout. Superior internal mechanism providing smooth operation.

- Available in 8m metric, 8m/26ft metric/imperial and 8m metric Easyread



# Sterling® SCRAPERS



Sterling®

## BRASS BUTTON - 80-200

High quality Made in USA. The most popular universal scraper. Blade cannot slide out during use which makes this scraper safer to use. Demanded by professionals.

Sterling are the market leaders in Single Edge Blades. Visit [sheffield.com.au](http://sheffield.com.au) for the full range

Sterling®

## SUPER DUTY SCRAPER

Extra comfortable rubber cushion grip handle with hammer end. Fits all 4" blades. 3 screws holds blade tightly and prevents slipping. Available in 450mm (18")



Sterling®

## RHINO-GRIP

Rubberised Rhino Grip handle provides comfortable secure grip even in wet areas. Quality polished stainless steel scraper blade has ideal flexibility and durability. Suitable for industrial and food applications. Available in 25mm (1"), 50mm (2"), 75mm (3") and 100mm (4"). Timber handle and carbon steel blade scrapers also available.

Sterling®

## TOUGH-SCRAPE - 4" SCRAPERS

Heavy duty wall and floor scraper. 3 screws holds blade tightly and prevents slipping. Comfortable cushion grip handle. 12" available with hammer end for difficult flooring take-ups. Available with 3 different handle lengths 300mm (12"), 450mm (18"), 1200mm (48").

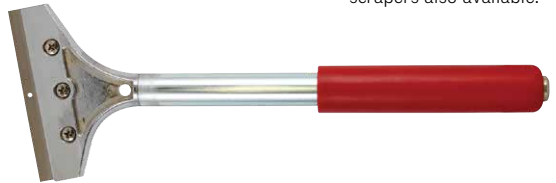

Sterling®

## PLASTIC SCRAPER - HDSCR

Most popular window scraper. Ergonomic angled head. Easy blade change. Comes with replaceable plastic cap that protects from injury but allows blade to dry. Easily attaches to extension poles. Replacement caps and blade holder available



F4 SUPER ALLWAY - Full range of Allway paint scrapers available



*Sterling*

### **RHINO GRIP GEL KNEE PADS - 18-530**

Anti-compression air injected gel pad. Super-thick, 1/2" high-density, closed-cell foam. Elastic straps with velcro fasteners for rapid fit.



*Sterling*

### **SOFT COMFI STYLE KNEE PADS - 18-550**

Elastic straps with velcro fasteners allows for a rapid fit for all, while the foam core gives maximum cushioning plus the benefit of perforated neoprene lining that works to keep all moisture away.

*Sterling*

### **CUSHION GRIP STAIR TOOL - 18-092**

Comfortable heavy duty cushion grip. Ideal for tucking carpet in confined spaces. Chrome plated steel to prevent marking skirting boards and carpets.



*Sterling*

### **ROW CUTTER - 18-002**

Takes heavy duty 3 hole technical blade. Ideal for cutting all jute/hessian back carpets. Reinforcing rib down front of cutter strengthens guiding nose. Strong durable nylon material for long life.

*Sterling*

### **BLACK PANTHER CARPET SHEARS**

Cracked handle shears. Stainless steel serrated edge blade. Angled handles keep hands above carpet and other sheet materials. Available in 250mm (10").



# Sterling® STAPLERS AND STAPLES

## TACKERS



### HEAVY DUTY HAMMER TACKER - AH-915

Heavy duty construction. Compact metal design with hardened steel parts. Single handed operation. Ergonomic rubber grip handle. Face protection guard ensures staples finish flush with workface. Easy bottom loading of staples.

Applications:

- Heavy duty insulation
- Plastic, carpet laying
- Sheeting and roofing
- General carpentry

## STAPLES



### A11 SERIES STAPLES

Available in standard / sharp point / stainless steel. 6 - 12mm high. Packed in resealable plastic boxes in quantities of 2000 and 5000

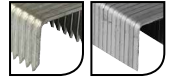
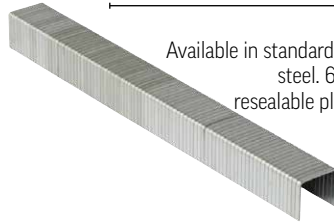

Reusable plastic boxes on most staple series, incl A11, 4000, 6000 series.



Sterling staples are available in the following series:

- A11 / 140 Series
- G5562 Series
- 4000 Series
- 6000 Series
- 13 Series
- 26 Series
- 73 Series
- Cable Staples

### PYTHON MULTI-FUNCTION STAPLE GUN - AT-901



Heavy duty, trade quality aluminium die cast body. Power adjustment control system. Ergonomic bi-material handle, reduces fatigue.

Low staple refill window - easy bottom loading of staples.

Supplied with 300 staples.

Safety handle lock.

Applications:

- Poster tacking and framing
- Upholstering and decorating
- Carpet and upholstery
- Insulation
- Commercial and household tacking jobs



## TAP & DIE HOLDERS

### ADJUSTABLE TAP & REAMER WRENCHES FORGED STEEL & CAST IRON BAR TYPE

- The straight handle design of these tap wrenches provides greater leverage, particularly useful when working with large diameter taps.
- Extra heavy duty. Industrial quality tap wrenches - virtually unbreakable Nr. 0,00, 5 & 6 have a FORGED STEEL BODY. Nr. 7 & 8 are cast from S.G. Iron.



Part No.	Code	Tap Capacity
<b>Forged Steel Tap &amp; Reamer Wrenches</b>		
GZ-09220	ARWR/SG/0	1 - 12mm
GZ-09221	ARWR/SG/00	1 - 6mm
GZ-09222	ARWR/SG/5	4 - 16mm
GZ-09223	ARWR/SG/6	4 - 20mm
<b>Cast Iron Tap &amp; Reamer Wrenches</b>		
GZ-09224	ARWR/SG/7	6 - 30mm
GZ-09225	ARWR/SG/8	9 - 45mm

### DIE STOCK HOLDERS STEEL CAST ROUND DIES

- Die holders are used for holding round dies, that are suited for efficient and clean cutting of external threads
- Die holders have a rugged construction



Part No.	Code	Die Size
GZ-09111	DS/0-1	1"
GZ-09113	DS/1-1-2	1-1/2"
GZ-09114	DS/0-2	2"

### TAP WRENCHES T HANDLE TYPE

- Industrial quality Tap Wrenches for the professional user.
- Designed to give the user the reach and leverage needed for accurate tapping, these are used for holding taps, drills, reamers & other small tools to be turned by hand.
- CNC machined to very close tolerances with self centring powder metallurgy hardened jaws & knurled chuck sleeve for positive grip.
- Ratchet handle can be set for right or left hand operation or locked for non ratchet use. Self centring powder metallurgy hardened jaws and knurled chuck sleeve provide positive grip on taps, reamers and small tools Sliding T – Handle for fitting into tight spaces with greater leverage.
- Also available with longer body for added leverage in hard to reach places.



Part No.	Code	Body Length	Capacity
<b>Tap Wrench Regular Length</b>			
GZ-09361	TW/164	70mm	1.6 - 6mm
GZ-09362	TW/166	95mm	6 - 12mm
<b>Ratchet Tap Wrench Regular Length</b>			
GZ-09371	TW/R/161	88mm	1.6 - 6mm
GZ-09372	TW/R/162	106mm	6 - 12mm
<b>Ratchet Tap Wrench Extra Long Length</b>			
GZ-09375	TW/R/161L	330mm	1.6 - 6mm
GZ-09376	TW/R/162L	330mm	6 - 12mm

**TM620-002  
HAND RIVETER**

- Durable steel body and handles
  - Chrome molybdenum steel collet
  - Comfortable rubber grip
- Nozzle sizes : 2.4mm, 3.2mm, 4.0mm, 4.8mm



**TM620-006  
ROTATING HEAD HAND RIVETER**

- Premium cast aluminium body
  - Chrome molybdenum steel collet
  - 360° Rotating head for hard to reach places
  - Durable powder coat finish
  - Comfortable rubber grip
- 4 Nozzles included: 2.4mm, 3.2mm, 4.0mm, 4.8mm



**TM620-004  
HEAVY DUTY HAND RIVETER**

- Premium cast aluminium body
  - Chrome molybdenum steel collet
  - Durable powder coat finish
  - Comfortable rubber grip
- 4 Nozzles included: 2.4mm, 3.2mm, 4.0mm, 4.8mm



**TM620-008  
EASY PULL TWIN HANDLE RIVETER**

- Premium quality
  - Strong aluminium alloy body
  - High impact long lasting PVC handle
  - Chrome molybdenum steel collet
  - 3 Jaw system
  - Durable powder coat finish
- 5 Nozzles : 3.2mm, 4.0mm, 4.8mm, 6.0mm & 6.4mm



**TM620-010  
SHORT ARM HAND RIVETER**

- Premium quality
  - Strong aluminium alloy body
  - High impact long lasting PVC handle
  - Chrome molybdenum steel collet
  - 3 Jaw system
  - Durable powder coat finish
- 5 Nozzles : 3.2mm, 4.0mm, 4.8mm, 6.0mm & 6.4mm



**TM620-012  
HEAVY DUTY LAZY TONG RIVETER**

- Premium quality
  - Single pull action designed for fast repetitive applications
  - Strong aluminium alloy body
  - Chrome molybdenum steel collet
  - 3 Jaw system
- 5 Nozzles : 3.2mm, 4.0mm, 4.8mm, 6.0mm & 6.4mm



Part No.	Aluminium Rivet Capacity	Steel Rivet Capacity	Stainless Steel Rivet Capacity
TM620-002	2.4mm (3/32") to 4.8mm (3/16")	2.4mm (3/32") to 4.8mm (3/16")	2.4mm (3/32") to 4.0mm (5/32")
TM620-004	2.4mm (3/32") to 4.8mm (3/16")	2.4mm (3/32") to 4.8mm (3/16")	2.4mm (3/32") to 4.0mm (5/32")
TM620-006	2.4mm (3/32") to 4.8mm (3/16")	2.4mm (3/32") to 4.8mm (3/16")	2.4mm (3/32") to 4.0mm (5/32")
TM620-008	3.2mm (1/8") to 6.4mm (1/4")	3.2mm (1/8") to 6.4mm (1/4")	3.2mm (1/8") to 6.0mm (15/64")
TM620-010	3.2mm (1/8") to 6.4mm (1/4")	3.2mm (1/8") to 6.4mm (1/4")	3.2mm (1/8") to 6.0mm (15/64")
TM620-012	3.2mm (1/8") to 6.4mm (1/4")	3.2mm (1/8") to 6.4mm (1/4")	3.2mm (1/8") to 6.4mm (1/4")



## TM620-014 SCREW NUT GUN

- Premium quality
- Light weight cast aluminium construction
- Single or two hand operation
- Easy change mandrels
- Sets 3, 4, 5 & 6mm rivet nuts



Part No.	Description
TM620-014	Screw Nut Gun

Magnetic Base Drilling Machines

Cutting Tools

Clamps

Engineer's Tools

Sharpening Machines

Metal Cutting Saws

Drilling Machines

Bevelling Machines & Welding Carriages

Punches & Shears

Grinding Machines

Fans & Ventilators

Workshop Storage

M7 Airtools

NPK Airtools

Pneumatic Products



# CLAMP SELECTION GUIDE

Image	Model	Span x Depth	Clamping Force	Pg #
	General Purpose Forged Steel Clamp	100 x 50mm to 1500 x 120mm	220kg to 1000kg	75
	Heavy Duty Forged Steel Clamp	300 x 140mm to 1500 x 175mm	1200kg to 2200kg	75
	High Force Forged Steel Clamp	200 x 80mm to 1000 x 120mm	1100kg to 2600kg	76
	Pivot Handle Forged Steel Clamp	200 x 100mm to 600 x 175mm	450kg to 700kg	76
	Quick Action Lever Forged Steel Clamp	160 x 80mm to 500 x 120mm	300kg to 550kg	76
	Beam Forged Steel Clamp	250 x 120mm to 500 x 175mm	550kg to 2200kg	76
	Quick Action Beam Forged Steel	250 x 120mm to 300 x 140mm	400kg to 500kg	77
	C Clamp Deep Throat Forged Steel Clamp	50 x 100mm to 250 x 400mm	600kg to 1000kg	77
	C Clamp General Purpose Forged Steel Clamp	100 x 50mm to 400 x 175mm	900kg to 2000kg	77
	C Clamp Heavy Duty Forged Steel Clamp	50 x 50mm to 200 x 90mm	1000kg to 4000kg	77
	Self Assembled Deep Throat Clamp	400 x 300mm to 1000 x 500mm	-	78
	Cantilever Forged Steel Clamp	300 x 100mm	700kg	79
	Cantilever C Clamp	-	130kg to 850kg	79
	Tool Maker's Parallel Clamp	30 x 50mm to 70 x 100mm	-	81
	Woodworker's Parallel Jaw Clamp	160 x 80mm to 600 x 80mm	200kg	81
	Premium Woodworker's Parallel Jaw Clamp	300 x 125mm to 2500mm x 125mm	710kg	81

Image	Model	Span x Depth	Clamping Force	Pg #
	Premium F Screw Cast Iron Clamp	120 x 60mm to 600 x 175mm	200kg to 1000kg	82
	F Screw Cast Iron Clamp	200 x 120mm to 800 x 120mm	-	82
	C Clamp Cast Iron	75 x 100mm to 300 x 100mm	-	82
	Bar Clamp & Spreader	150 x 85mm to 600 x 85mm	-	83
	Spring Clamp	30 x 25mm to 80 x 70mm	-	83
	Quick Release Hand Clamp	50 x 55mm to 75 x 85mm	-	83
	Multi Adjustment Clamp	180 x 60mm to 260 x 120mm	-	83
	Quick Gear Clamp	80 x 300mm	-	83
	Cast Alloy Quick Lever Bar Clamp	150 x 85mm to 600 x 85mm	400kg	84
	Cast Alloy Multi Function Bar Clamp	150 x 85mm to 600 x 85mm	400kg	84
	Locking Plier	-	-	84
	Locking C Clamps With Swivel Pads	-	-	84
	Locking Welding Clamp	-	-	84
	Sash Bar Cramp	450 x 50mm to 1200 x 50mm	-	85
	Cramp Head Set	-	-	85
	Sash Cramp Heavy Duty	750 x 48mm to 1980 x 48mm	-	85

# FORGED STEEL WELDING CLAMPS

## GENERAL PURPOSE FORGED STEEL CLAMP

For general duty clamping applications. Swivel pad ensures even pressure is applied on angular workpieces.

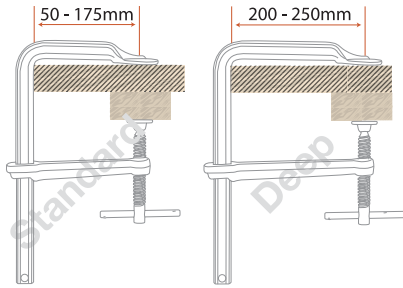

## HEAVY DUTY FORGED STEEL CLAMP

Larger rail sizes & acme spindle  
For heavy duty applications.

- Changeable clamping heads
- Socket drive handle

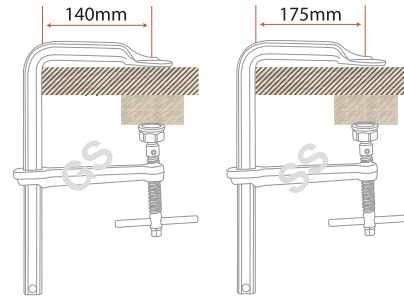

### Heavy Duty Clamp Features

- Socket Drive Handle
- Changeable Clamp Heads

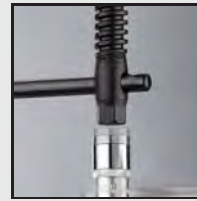

STANDARD DEPTH			
Part No.	Span x Depth	Rail Size	Clamping Force
EC-G10CS	100 x 50mm	11.5 x 5.7mm	220kg
EC-G16CS	160 x 80mm	16 x 7.5mm	300kg
EC-G20CS	200 x 100mm	19.5 x 9.5mm	450kg
EC-G25CS	250 x 120mm	22 x 10.5mm	550kg
EC-G30CS	300 x 140mm	25 x 12mm	670kg
EC-SG40CS	400 x 120mm	25 x 12mm	750kg
EC-G40CS	400 x 175mm	27 x 13mm	1000kg
EC-SG50CS	500 x 120mm	25 x 12mm	750kg
EC-SG60CS	600 x 120mm	25 x 12mm	750kg
EC-G60CS	600 x 175mm	27 x 13mm	1000kg
EC-SG80CS	800 x 120mm	27 x 13mm	1000kg
EC-G80CS	800 x 175mm	27 x 13mm	1000kg
EC-G100CS	1000 x 175mm	27 x 13mm	1000kg
EC-SG125CS	1250 x 120mm	27 x 13mm	1000kg
EC-SG150CS	1500 x 120mm	27 x 13mm	1000kg

EXTRA DEPTH			
Part No.	Span x Depth	Rail Size	Clamping Force
EC-SD30T20	300 x 200mm	30 x 15mm	800kg
EC-SD50T25	500 x 250mm	30 x 15mm	700kg
EC-SD100T25	1000 x 250mm	30 x 15mm	700kg

GS SERIES HEAVY DUTY			
Part No.	Span x Depth	Rail Size	Clamping Force
EC-GS30C	300 x 140mm	30 x 15mm	1200kg
EC-GS40C	400 x 120mm	30 x 15mm	1200kg
EC-GS50C	500 x 140mm	30 x 15mm	1200kg
EC-GS60C	600 x 120mm	30 x 15mm	1200kg
EC-GS80C	800 x 140mm	30 x 15mm	1200kg
EC-GS100C	1000 x 120mm	30 x 15mm	1200kg

SS SERIES EXTRA HEAVY DUTY			
Part No.	Span x Depth	Rail Size	Clamping Force
EC-SS30C	300 x 175mm	40 x 20mm	2200kg
EC-SS40C	400 x 175mm	40 x 20mm	2200kg
EC-SS50C	500 x 175mm	40 x 20mm	2200kg
EC-SS60C	600 x 175mm	40 x 20mm	2200kg
EC-SS100C	1000 x 175mm	40 x 20mm	2200kg
EC-SS150C	1500 x 175mm	40 x 20mm	2200kg

**OPTIONAL PLASTIC SOFT PADS AVAILABLE. PROTECT YOUR WORKPIECE! SEE PAGE 80**





## HIGH FORCE FORGED STEEL CLAMP

Larger rail sizes & shorter depths giving high clamping force. Knurled clamping face & pad provide stronger grip on the workpiece.

- Socket Drive Handle Featured On Clamps With 30mm Or 40mm Rail Size



- Knurled Pads

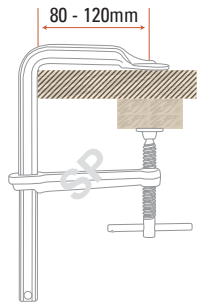

Part No.	Span x Depth	Rail Size	Clamping Force
EC-SP20C8	200 x 80mm	27 x 13mm	1100kg
EC-SP25C8	250 x 80mm	27 x 13mm	1100kg
EC-SP30C8	300 x 80mm	27 x 13mm	1100kg
EC-SP25C10	250 x 100mm	30 x 15mm	1400kg
EC-SP40C10	400 x 100mm	30 x 15mm	1400kg
EC-SP60C10	600 x 100mm	30 x 15mm	1400kg
EC-SP30C12	300 x 120mm	40 x 20mm	2600kg
EC-SP50C12	500 x 120mm	40 x 20mm	2600kg
EC-SP100C12	1000 x 120mm	40 x 20mm	2600kg

## PIVOT HANDLE FORGED STEEL CLAMP

The comfortable pivot handle makes it easier to achieve maximum clamping pressure & allows faster clamping in restricted working areas.

- Easy Operation In Restricted Working Areas

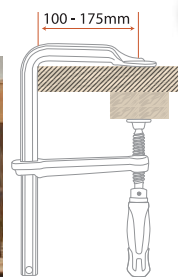
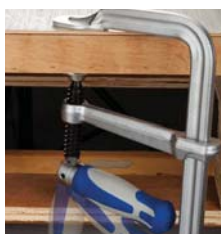

Part No.	Span x Depth	Rail Size	Clamping Force
EC-REG20C	200 x 100mm	19.5 x 9.5mm	450kg
EC-REG30C	300 x 140mm	25 x 12mm	670kg
EC-REG40C	400 x 175mm	27 x 13mm	700kg
EC-REG60C	600 x 175mm	27 x 13mm	700kg

## QUICK ACTION LEVER FORGED STEEL CLAMP

Ratchet type lever prevents overloading & resists vibration. For high pressure, fast action clamping purposes.

- Fast & Easy To Use

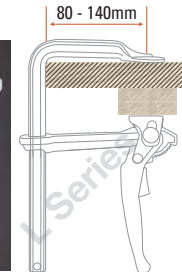

Part No.	Span x Depth	Rail Size	Clamping Force
EC-G16L	160 x 80mm	16 x 7.5mm	300kg
EC-G20L	200 x 100mm	19.5 x 9.5mm	350kg
EC-G30L	300 x 140mm	25 x 12mm	500kg
EC-G40L	400 X 120mm	25 x 12mm	550kg
EC-G50L	500 x 120mm	25 x 12mm	550kg

## BEAM FORGED STEEL CLAMP

U-Turn design is ideal for clamping H beam when welding

- Changeable Heads



- Socket Drive Handle

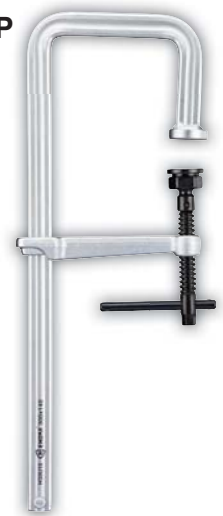
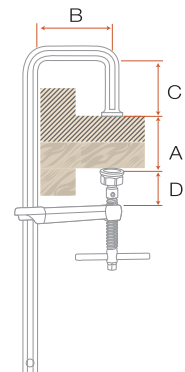

Part No.	Span x Depth (A x B)	U Depth (C)	Overpass (D)	Rail Size	Clamping Force
EC-H25U6	250 x 120	60	90	22 x 10.5	550kg
EC-H30U10	300 x 140	100	100	25 x 12	650kg
EC-H30U11	300 x 140	110	115	30 x 15	1100kg
EC-H50U11	500 x 140	110	115	30 x 15	1100kg
EC-H30U15	300 x 175	150	130	40 x 20	2200kg
EC-H40U15	400 x 175	150	130	40 x 20	2200kg
EC-H50U15	500 x 175	150	130	40 x 20	2200kg

### QUICK ACTION BEAM FORGED STEEL CLAMP

As above with Ratchet type lever to prevent overloading & resist vibration. For high pressure, fast action clamping purposes

• Fast & Easy To Use

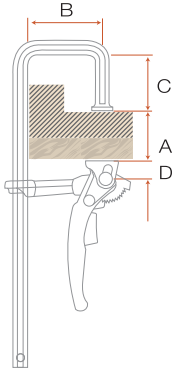

Part No.	Span x Depth (A x B)	U Depth (C)	Overpass (D)	Rail Size	Clamping Force
EC-H25U6L	250 x 120	60	10	22 x 10.5	400kg
EC-H30U10L	300 x 140	100	12	25 x 12	500kg

### C CLAMP DEEP THROAT FORGED STEEL CLAMP

As per standard General Purpose C Clamp, with increased depth capacity



Part No.	Span x Depth	Rail Size	Clamping Force
EC-UC2	50 x 100mm	19.5 x 9.5mm	600kg
EC-UC3	75 x 125mm	22 x 10.5mm	600kg
EC-UC4	100 x 160mm	25 x 12mm	650kg
EC-UC5	125 x 200mm	27 x 13mm	700kg
EC-UC6	150 x 250mm	30 x 15mm	800kg
EC-UC8	200 x 350mm	36 x 18mm	850kg
EC-UC10	250 x 400mm	40 x 20mm	1000kg

### C CLAMP GENERAL PURPOSE FORGED STEEL CLAMP

These General Duty C Clamps are suitable for a wide range of applications.

- Hardened Acme Spindle
- Swivel pad ensures even pressure is applied on angular workpieces.

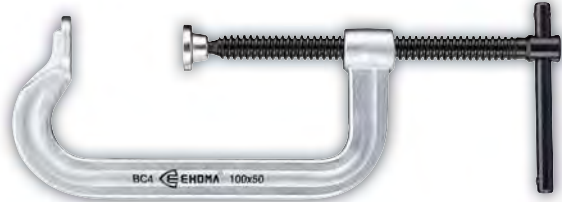

Part No.	Span x Depth	Rail Size	Clamping Force
EC-BC4	100 x 50mm	19.5 x 9.5mm	900kg
EC-BC5	125 x 65mm	19.5 x 9.5mm	850kg
EC-BC6	150 x 75mm	22 x 10.5mm	1000kg
EC-BC8	200 x 100mm	25 x 12mm	1000kg
EC-BC10	250 x 115mm	27 x 13mm	1200kg
EC-BC12	300 x 125mm	30 x 15mm	1500kg
EC-BC14	350 x 150mm	36 x 18mm	1800kg
EC-BC16	400 x 175mm	40 x 20mm	2000kg

### C CLAMP HEAVY DUTY FORGED STEEL CLAMP

- Larger rail sizes & Acme spindle for heavy duty applications
- Swivel pad ensures even pressure is applied on angular workpieces



Part No.	Span x Depth	Rail Size	Clamping Force
EC-CT-2	50 x 50mm	19.5 x 9.5mm	1000kg
EC-CT-3	75 x 50mm	22 x 10.5mm	1300kg
EC-CT-4	100 x 60mm	25 x 12mm	1500kg
EC-CT-6	150 x 75mm	27 x 13mm	2200kg
EC-CT-8	200 x 90mm	30 x 15mm	4000kg

**CAST IRON C CLAMPS AVAILABLE. SEE PAGE 82**



## SELF ASSEMBLED DEEP THROAT CLAMP

The post rail & arms are purchased separately to create a clamp that best suits your needs. Multiple arms can be attached to the post rail, as uniform rail size allows use of all arms on all post rails.



POST RAIL		
Part No.	Span ( Length )	Rail Size
EC-PR36040	400mm	36 x 18mm
EC-PR36060	600mm	36 x 18mm
EC-PR36080	800mm	36 x 18mm
EC-PR36100	1000mm	36 x 18mm

FIXED & SLIDING ARM SET		
Part No.	Depth	To Suit Rail Size
EC-DSFAT363	300mm	36 x 18mm
EC-DSFAT364	400mm	36 x 18mm
EC-DSFAT365	500mm	36 x 18mm

SLIDING ARM		
Part No.	Depth	To Suit Rail Size
EC-DSAT3630	300mm	36 x 18mm
EC-DSAT3640	400mm	36 x 18mm
EC-DSAT3650	500mm	36 x 18mm

## JOINT BLOCK & EXTENSION RAIL

Extend your clamping span by 1000mm. Suitable for use with all Ehoma Clamps with the equivalent rail size



EXTENSION RAIL		
Part No.	Length	Rail Size
EC-CR27100	1000mm	27 x 13mm
EC-CR30100	1000mm	30 x 15mm
EC-CR36100	1000mm	36 x 18mm
EC-CR40100	1000mm	40 x 20mm



JOINT BLOCK	
Part No.	To Suit Rail Size
EC-CJB27	27 x 13mm
EC-CJB30	30 x 15mm
EC-CJB36	36 x 18mm
EC-CJB40	40 x 20mm

### CANTILEVER CLAMP FORGED STEEL CLAMP

Obtain maximum clamping pressure with minimum tightening force. Designed for clamping inward & outward in various applications.

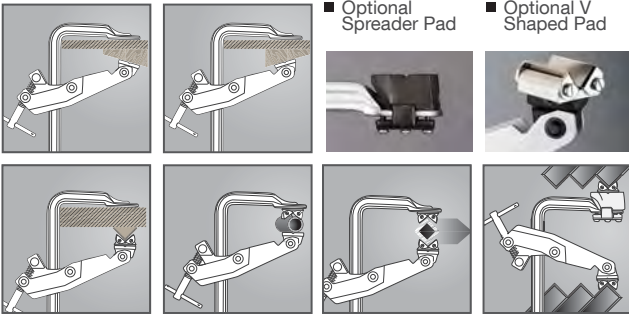
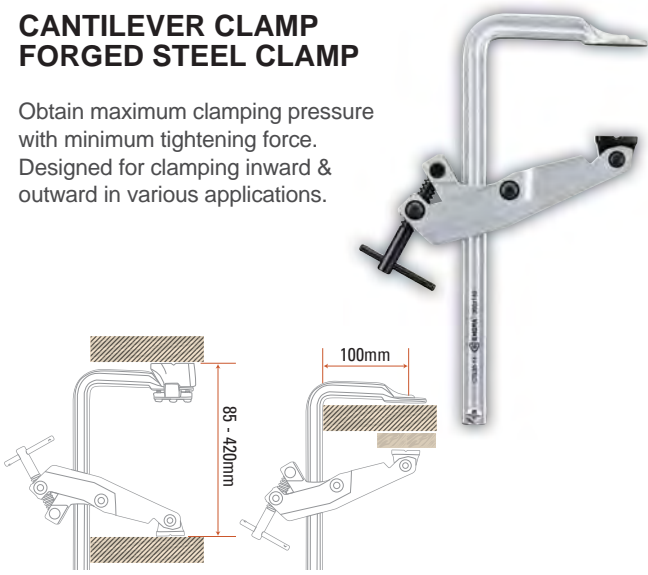

Part No.	Span x Depth	Rail Size	Clamping Force
<b>EC-CTL30</b>	300 x 100mm	27 x 13mm	700kg
<b>EC-CTD-2</b>	Spreader Pad To Suit Cantilever Clamp		
<b>EC-CTV</b>	V Shaped Pressure Pad To Suit Cantilever Clamp		

### C CLAMP CANTILEVER FORGED STEEL CLAMP

- Cantilever clamping action, which removes the handle away from the work area
- 4 Sided Swivel Pads
- Quick adjust function on ECCTC-4.5 & ECCTC-6

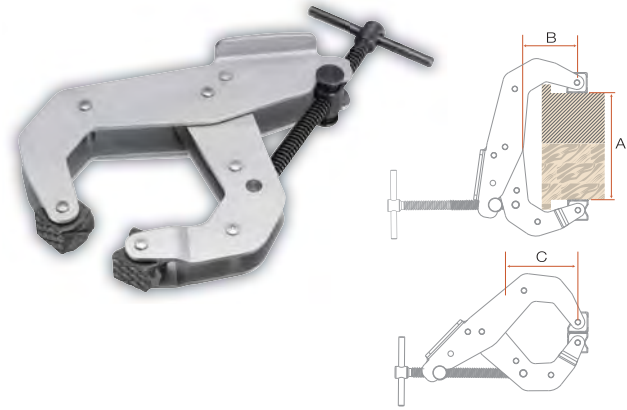

Part No.	Span (A)	Depth (B)	Depth (C)	Clamping Force
<b>EC-CTC-1</b>	25mm	15mm	20mm	130kg
<b>EC-CTC-2</b>	50mm	33mm	42mm	310kg
<b>EC-CTC-3</b>	75mm	35mm	49mm	500kg
<b>EC-CTC-4.5</b>	110mm	58mm	78mm	680kg
<b>EC-CTC-6</b>	150mm	110mm	128mm	850kg

# CLAMP PARTS

## PADS

Replacement pressure pad to suit General Purpose Clamps, Pivot Handle Clamp & C Clamps



Part No.	To Suit Rail Size
<b>EC-PAD16CS</b>	EC-G16CS
<b>EC-PAD20CS</b>	EC-G20CS, EC-G25CS,
<b>EC-PAD30CS</b>	EC-G30CS, EC-SG40CS, EC-G40CS, EC-SG50CS, EC-SG60CS, EC-G60CS, EC-SG80CS, EC-G80CS, EC-G100CS, EC-SG125CS, EC-SG150CS

## PIVOT HANDLE

Includes Handle, Pin, Ball Bearing, Spring



Part No.	To Suit Clamps
<b>ECP-ESP16RSET</b>	EC-REG20C
<b>ECP-ESP18RSET</b>	EC-REG30C, EC-REG40C, EC-REG60C

## QUICK LEVER

Includes Lever, Handle, Trigger



Part No.	To Suit Clamps
<b>ECP-ESP20LSET</b>	EC-G20L
<b>ECP-ESP30LSET</b>	EC-G30L, EC-G40L, EC-G50L

## HEAVY DUTY PADS

To suit Heavy Duty Clamp & Beam Clamp

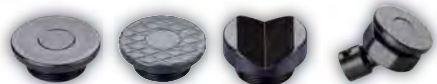

ECGSP ECGSR ECGSV ECGSPADASSY

Part No.	To Suit Rail Size
<b>EC-GSP</b>	30x15, 40x20mm
<b>EC-GSR</b>	30x15, 40x20mm
<b>EC-GSV</b>	30x15, 40x20mm
<b>EC-GSPADASSY</b>	30x15, 40x20mm

## HEAVY DUTY SPINDLE & T-BAR

To suit Heavy Duty Clamp



Part No.	To Suit Rail Size
<b>ECP-ESP30ST-H</b>	30.0mm
<b>ECP-ESP40ST-H</b>	40.0mm

## HEAVY DUTY ARM ASSEMBLY

Includes Arm, Spindle, T-Bar, Pad



Part No.	To Suit Rail Size	Depth
<b>ECP-ESP3014AST-P</b>	30.0mm	140mm
<b>ECP-ESP4017AST-P</b>	40.0mm	175mm

## SOFT PADS

This 2 piece soft pad set is simply placed over your existing pad & is designed to stop clamps marking softer surfaces.



Part No.	To Suit Clamps
<b>EC-PPAD20</b>	EC-G20CS, EC-REG20C
<b>EC-PPAD30</b>	EC-G30CS, EC-SG40CS, EC-G40CS, EC-SG50CS, EC-SG60CS, EC-G60CS, EC-SG80CS, EC-G80CS, EC-REG30C, EC-REG40C, EC-REG50C, EC-REG60C

## SPINDLE & T-BAR

To suit General Purpose Clamp

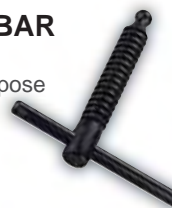

Part No.	To Clamp
<b>ECP-ESP10TH</b>	EC-G10CS
<b>ECP-ESP14TH</b>	EC-G16CS
<b>ECP-ESP16TH</b>	EC-G20CS, EC-G25CS,
<b>ECP-ESP18TH</b>	EC-G30CS, EC-SG40CS, EC-G40CS, EC-SG50CS, EC-SG60CS, EC-G60CS, EC-SG80CS, EC-G80CS, EC-G100CS, EC-SG125CS, EC-SG150CS

## GENERAL PURPOSE ARM ASSEMBLY

Includes Arm, Spindle, T-Bar, Pad



Part No.	To Suit Rail Size	Depth
<b>ECP-ESP1105AST</b>	11.5mm	50mm
<b>ECP-ESP1608AST</b>	16.0mm	80mm
<b>ECP-ESP1910AST</b>	19.5mm	100mm
<b>ECP-ESP2212AST</b>	22.0mm	120mm
<b>ECP-ESP2512AST</b>	25.0mm	120mm
<b>ECP-ESP2514AST</b>	25.0mm	140mm
<b>ECP-ESP2712AST</b>	27.0mm	120mm
<b>ECP-ESP2717AST</b>	27.0mm	175mm

## TOOL MAKER'S PARALLEL CLAMPS

### TOOL MAKER'S PARALLEL JAW CLAMP

- Manufactured from case hardened steel 45 ± 5HRC . Parallel Clamps are designed for maximum strength and rigidity
- All sizes are equipped with a spring clip
- A retaining ring holds the loose jaw in alignment when the clamp is being opened or closed. The ends of the jaws are rounded to permit clamping under shoulders or in recesses
- These clamps are extremely useful for holding work together in tapping, drilling & on various machine setups



Part No.	Code	Span x Depth
GZ-35601	PC/1	30 x 50mm
GZ-35602	PC/2	44 x 63mm
GZ-35603	PC/3	56 x 75mm
GZ-35604	PC/4	70 x 100mm

## WOODWORKER'S PARALLEL CLAMPS

### WOODWORKER'S PARALLEL JAW CLAMP

- The large clamping area and parallel jaws allow secure even clamping of the work piece and prevent damage
- Anti-slip system prevents the lower rail slipping or un-clamping
- Can be used as a spreader



Part No.	Span x Depth	Spreading	Rail Size	Weight	Clamping Force
EC-PJ16	160 x 80mm	172-270mm	20 x 5mm	0.6kg	200kg
EC-PJ30	300 x 80mm	172-415mm	20 x 5mm	0.7kg	200kg
EC-PJ60	600 x 80mm	172-720mm	20 x 5mm	0.9kg	200kg

### PREMIUM WOODWORKER'S PARALLEL JAW CLAMP

- The large clamping area and parallel jaws allow secure & even clamping of the work piece and prevents damage
- Anti-slip system prevents the lower rail slipping or un-clamping
- Workpiece platform prevents direct contact between the workpiece and the rail
- Replaceable pressure caps protect delicate surfaces and are resistant to glue, paint and grease solvents
- Can be used as a spreader
- Large 29mm x 9mm rail size



Part No.	Span x Depth	Spreading	Weight	Clamping Force
EC-PJH30	300 x 125mm	245-435mm	2.03kg	710kg
EC-PJH60	600 x 125mm	245-735mm	2.57kg	710kg
EC-PJH80	800 x 125mm	245-935mm	2.93kg	710kg
EC-PJH100	1000 x 125mm	245-1135mm	3.28kg	710kg
EC-PJH125	1250 x 125mm	245-1385mm	3.73kg	710kg
EC-PJH150	1500 x 125mm	245-1635mm	4.18kg	710kg
EC-PJH200	2000 x 125mm	245-2135mm	5.07kg	710kg
EC-PJH250	2500 x 125mm	245-2635mm	5.96kg	710kg

# CAST IRON CLAMPS

## PREMIUM F SCREW CLAMP

- Premium quality F screw clamp manufactured by Ehoma
- High-quality profiled rail, serrated to prevent slipping
- Malleable cast iron arms
- Two piece comfortable handle
- Replaceable rubber pressure pads both on the head and clamping pad

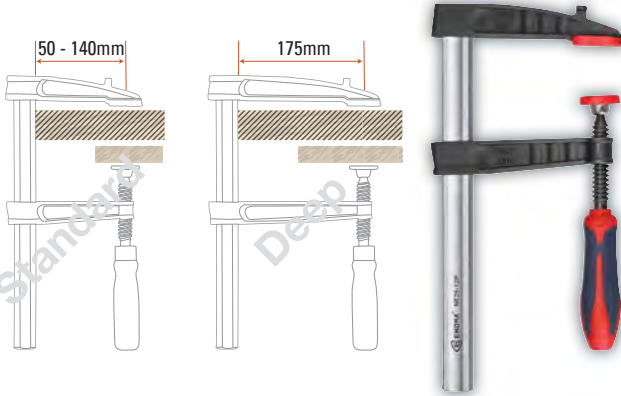

Part No.	Span x Depth	Rail Size	Clamping Force
EC-NB12-6P	120 x 60mm	20 x 5mm	200kg
EC-NC16-8P	160 x 80mm	25 x 6mm	270kg
EC-ND20-10P	200 x 100mm	27 x 7mm	400kg
EC-NE25-12P	250 x 120mm	29 x 9mm	500kg
EC-NF30-14P	300 x 140mm	32 x 10mm	550kg
EC-NF40-17P	400 x 175mm	32 x 10mm	1000kg
EC-NF60-17P	600 x 175mm	32 x 10mm	1000kg

## F SCREW CLAMP

- Malleable cast jaws for strength and durability
- Serrated slip resistant profiled rail
- Rubber grip handle
- Removable soft pads



Part No.	Span x Depth
TC-F200120	200 x 120mm
TC-F250120	250 x 120mm
TC-F300120	300 x 120mm
TC-F400120	400 x 120mm
TC-F500120	500 x 120mm
TC-F600120	600 x 120mm
TC-F800120	800 x 120mm

## C CLAMP

- Cast iron construction



Part No.	Span x Depth
TC-C075	75 x 100mm
TC-C100	100 x 100mm
TC-C150	150 x 100mm
TC-C200	200 x 100mm
TC-C250	250 x 100mm
TC-C300	300 x 100mm

# MULTI PURPOSE CLAMPS

## BAR CLAMP & SPREADER



- Durable plastic construction
- Removable rubber pressure pads
- Rubber grip handle
- Quick release lever
- Head can be placed on opposite end to create a spreader

Part No.	Span x Depth	Spreading Capacity
TC-6PT	150 x 85mm	167 - 350mm
TC-12PT	300 x 85mm	167 - 500mm
TC-18PT	450 x 85mm	167 - 650mm
TC-24PT	600 x 85mm	167 - 800mm

## QUICK GEAR CLAMP

- Quick gear clamping and releasing mechanism
- Removable pads



Part No.	Span x Depth	Rail Size
TC-QG12	80 x 300mm	19 x 6mm

## SPRING CLAMP

- Durable plastic construction
- Light weight
- Soft rubber handle
- Extra strong grip



Part No.	Span x Depth
TC-SP3	30 x 25mm
TC-SP4	40 x 35mm
TC-SP6	60 x 55mm
TC-SP9	80 x 70mm

## QUICK RELEASE HAND CLAMP



- Durable plastic construction & metal locking mechanism
- Swivel pads
- Serrated edge
- Quick release lever

Part No.	Span x Depth
TC-107	50 x 55mm
TC-109	75 x 85mm

## MULTI ADJUSTMENT CLAMP



- Durable plastic construction & metal locking mechanism
- Movable arm positions to best suit the application
- Quick release lever
- Rubber grip handle
- Swivel pads

Part No.	Span x Depth
TC-0179	180 x 60mm
TC-0169	260 x 100mm
TC-0159	260 x 120mm



**QUICK LEVER BAR CLAMP  
CAST ALLOY CONSTRUCTION**

This clamp has all of the great features of the multi function one hand bar clamp & spreader, but with a single action quick clamping mechanism.

Slide the tool into position, then clamp the work with one movement of the lever!

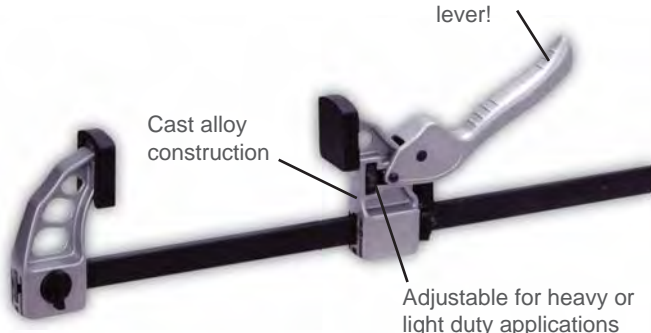

Part No.	Span x Depth	Spreading Capacity	Clamping Force
EC-TC-6HA	150 x 85mm	170 - 365mm	400kg
EC-TC-12HA	300 x 85mm	170 - 515mm	400kg
EC-TC-18HA	450 x 85mm	170 - 665mm	400kg
EC-TC-24HA	600 x 85mm	170 - 815mm	400kg

**CAST ALLOY BAR CLAMP  
MULTI FUNCTION**



Part No.	Span x Depth	Spreading Capacity	Clamping Force
EC-TC-6A	150 x 85mm	170 - 365mm	400kg
EC-TC-12A	300 x 85mm	170 - 515mm	400kg
EC-TC-18A	450 x 85mm	170 - 665mm	400kg
EC-TC-24A	600 x 85mm	170 - 815mm	400kg

**LOCKING CLAMPS  
& PLIERS**

**LOCKING PLIER**



Part No.	Description
H304	10" Locking Plier

**LOCKING C CLAMPS WITH SWIVEL PADS**



Part No.	Description
H307/11SP	11" Locking "C" Clamp With Swivel Pads
H307/18SP	18" Locking "C" Clamp With Swivel Pads

**LOCKING WELDING CLAMP**



Part No.	Description
H313	9" Locking Welding Clamp

# SASH CRAMPS

## SASH BAR CRAMPS

Bar cramps are especially useful for clamping large section workpieces during fabrication, gluing in joinery, carpentry and boat building.

The bars are made from drawn steel with a section of 32mm x 6mm. Malleable iron head and slides provide rigidity and strength even under heavy tension. Both head and slide have a flat bottom allowing the bar to stand upright without support. The head is fitted square to the bar with 1.5° to 2° taper for true parallel clamping action.

Main screw and handle are made from high-grade steel and have a blackened finish for increased resistance to corrosion. The screw has rolled Acme threads that impart extra strength and are wear resistant.

Features:

- Throat depth : 50mm (2")
- Width of clamp face : 30mm (1-3/16")

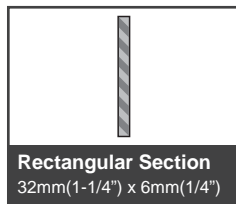

Part No.	Code	Bar Length	Clamping Capacity
GZ-39110	SBC/24	600mm	450mm
GZ-39111	SBC/30	750mm	600mm
GZ-39112	SBC/36	900mm	750mm
GZ-39113	SBC/42	1050mm	900mm
GZ-39114	SBC/48	1200mm	1050mm
GZ-39115	SBC/54	1350mm	1200mm

## CRAMP HEAD SET

Cramp heads are a low cost alternative to the full size T Bar and Sash Bar Cramps. A bar cramp of any length can be made by using a piece of timber 25mm(1") thick. The timber is drilled with holes producing a light duty bar cramp as strong and as true as the timber chosen. The heads are made from malleable iron, the handle screw and pin from high quality steel for hard wearing long life. Blackened screw has rolled Acme threads for extra strength and resistance to wear.

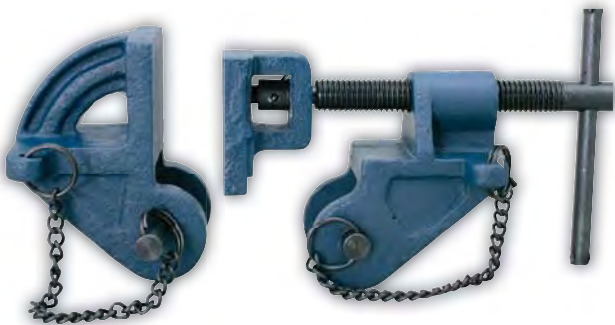

Part No.	Code	Description
GZ-39120	CHST/25-25	Cramp Head Set

## SASH CRAMPS HEAVY DUTY T BAR

A robust set of cramps designed for applications that require extra resilience under extreme pressure, these can be permanently fixed onto the workbench as well.

The "T" section bar is made from special cold drawn steel with a section of 41mm x 25mm which offers great resistance to bending in use. Malleable iron head and slide allow these cramps to be used in extra heavy duty applications. The main screw has rolled Acme threads for smooth movement and increased resistance to wear. The sliding head is fastened to the T Bar by inserting a steel pin through any of the locating holes on the bar. The main screw, handle and pins are blackened for increased resistance to corrosion.

Features:

- Throat depth : 48mm (1-7/8")
- Width of clamp face : 54mm (2-1/8")

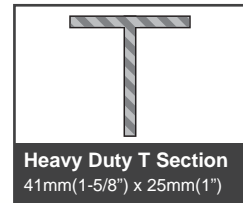

Part No.	Code	Bar Length	Clamping Capacity
GZ-39100	TBC/3	900mm	750mm
GZ-39101	TBC/4	1200mm	1050mm
GZ-39102	TBC/5	1500mm	1350mm
GZ-39103	TBC/6	1800mm	1650mm
GZ-39151	TBC/7	2100mm	1980mm

## MACHINIST'S SQUARES

- Whilst ideal for everyday workshop use, these are also suitable for woodworking applications.
- Made from high grade steel with hardened blade, these squares have accurate right angles both on the inside and outside.
- Both the blade and stock are accurately ground which ensures straightness and parallelism.



Part No.	Code	Blade Length L1	Blade Length L2	Squareness of blade edges to working faces of stock (microns)
GZ-01100	SS/2	50mm	50mm	48
GZ-01101	SS/3	75mm	60mm	48
GZ-01102	SS/4	100mm	75mm	48
GZ-01103	SS/6	150mm	100mm	72
GZ-01104	SS/8	200mm	125mm	72
GZ-01106	SS/10	250mm	165mm	72
GZ-01107	SS/12	300mm	210mm	96

## MACHINIST'S SQUARE SET

- Includes 50, 75, 100 & 150mm



Part No.	Code	Description
GZ-01110	SS/2-3-4-6/ST	Machinist's Square Set, 4 piece 50, 75, 100, 150mm

## STRAIGHT EDGES

- Manufactured from high quality spring steel, Straight Edges are fully ground and hand scraped for a perfectly flat surface, making these an extremely accurate tool.
- Used for drawing & scribing straight lines, checking surfaces for straightness, setting up machines such as planers etc.
- Straight Edges have flat edges on both sides.



Straight Edge being used to check flatness of an engine block.

Part No.	Code	Dimensions	Flatness of Edges (Microns)	Parallelism of Faces (Microns)
GZ-02500	SE/12	300 x 36 x 8mm	12	24
GZ-02501	SE/18	450 x 36 x 8mm	12	24
GZ-02502	SE/24	600 x 36 x 8mm	17	33
GZ-02503	SE/36	900 x 61 x 10mm	21	40
GZ-02504	SE/48	1200 x 61 x 10mm	28	50
GZ-02505	SE/60	1500 x 80 x 10mm	28	50
GZ-02506	SE/72	1800 x 80 x 10mm	38	74

## TOOL MAKER'S VEE BLOCK & CLAMP SETS

- Manufactured from high grade tool steel fully hardened to 55-60 HRC.
- Manufactured and numbered in matched pairs, each pair has two 90° Vees of different capacities which are identical to the Vees of its matching block. The Vee's are ground central, parallel and square with the ends and sides.
- These Vee Blocks are very useful for holding work securely during drilling, milling and grinding operations and also in layout and inspection work. Each pair of Vee Blocks comes complete with a pair of rigid and robust clamps.
- Available in two types: Regular type and Non protruding clamp type. Top clamping design of the Non protruding clamp type allows the blocks to be used on the side faces in addition to the base.

Vee Blocks & Clamp Sets  
- Regular



Vee Blocks & Clamp Sets -  
Non Protuding Clamp Type

- Permissible Height difference between matched pairs  
- Within 0.0002" (5 microns)
- Parallelism and Squareness of Vee grooves with respect to all surfaces  
- Within 0.0003" (8 microns)
- Parallelism of opposite faces of Vee Blocks  
- Within 0.0003" (8 microns)
- Squareness of adjacent exterior faces of Vee Blocks  
- Within 0.0003" (8 microns)
- Flatness of Working Faces  
- Within 0.0002" (5 microns)

Part No.	Code	Dimensions	Capacity
<b>Vee Blocks &amp; Clamps - Regular Type</b>			
GZ-03000	VB/T/30	40 x 32 x 32mm	25mm
GZ-03001	VB/T/35	50 x 37 x 37mm	32mm
GZ-03004	VB/T/70	70 x 45 x 37mm	37mm
<b>Vee Blocks &amp; Clamps - Non Protuding Type</b>			
GZ-03080	VB/SP/R/T/70	70 x 63 x 45mm	37mm

## VEE BLOCKS - CAST IRON

- Made from close grained cast iron, these blocks are precisely ground and machined square and parallel.
- The Vee's are 90° centred in true.
- The blocks are manufactured and supplied in numbered pairs and come in handy for holding large jobs where clamping is not necessary.



Squareness and Parallelism of Vee Grooves with respect to base

- Within 0.0012" (30 microns)

Part No.	Code	Dimensions	Vee Width
GZ-03101	VB/C/4	100 x 40 x 65mm	56mm
GZ-03103	VB/C/6	150 x 62 x 88mm	78mm

**FOR GROZ CRAMPS AND PARALLEL CLAMPS SEE PAGES 81 & 85**



## VEE BLOCK & CLAMP SETS

- Manufactured from high grade tool steel fully hardened to 55-60 HRC.
- The special design with 90° Vee angle provides a quick, accurate and positive means of holding workpieces for machining, grinding and in layout and inspection work.
- In addition to use on base, the Vee block can also be used on its side or end.
- The unit comes complete with a reversible swing away style clamp that clamps against almost any shape of product.
- The three tapped hole positions in the Vee block for the clamp allows the clamp to be positioned at either end or at the centre of the Vee block.
- Tapped holes on the Vee block end allow mounting the block perpendicular to the face plate. Each unit comes complete with the basic block, reversible clamp and 2 clamp screws.
- Also available in matched pairs with 2 block, 2 clamps and 4 screws.



- Parallelism and Squareness of Vee Grooves with respect to the base  
- Within 0.0003" (8 microns)
- Matched Pair Tolerance  
- Within 0.0002" (5 microns)



Versatile Vee Block allows reversal of clamp to facilitate clamping of jobs with a smaller diameter or irregular form.

Part No.	Code	Description	Dimensions	Capacity
GZ-03092	VB/SP/V/100S	Single	100 x 75 x 75mm	57mm
GZ-03093	VB/SP/V/100P	Matched Pair	100 x 75 x 75mm	57mm

## ADJUSTABLE ANGLE BLOCK 0° - 60°

- Made from fully hardened (50-55 HRC) and ground tool steel, these precision Adjustable Angle Blocks are useful for most drilling, milling and set up jobs where a particular angle to a reference face is required.
- The block is fully adjustable from 0°-60° and can be set at any desired position by locking of the hex screw located in the base.
- Angle Accuracy :  $\pm 1.0^\circ$ .
- Squareness : 0.0004" (10 microns).



Part No.	Code	Angle	Dimensions
GZ-02100	PAB/01/A	0° - 60°	95 x 45 x 50mm

## MAGNETIC VEE BLOCKS

- Designed for versatility and accuracy, these Vee Blocks are ideal for holding round or irregular shapes for scribing, grinding, measuring, machining and testing applications.
- All Vee's and faces can be energised or de energised simultaneously by turning the rotary action control knob. This feature enables the Vee Block to hold both itself and the work on any flat ferrous surface including a permanent magnetic chuck (without energising the chuck). Brass knob ensures no interference with the magnetic field.
- For applications requiring two Vee blocks matched and numbered pairs are available



Part No.	Code	Description	Dimensions	Capacity
GZ-02900	MVB/4S	Single	100 x 75 x 95MM	70mm
GZ-02901	MVB/4P	Matched pair	100 x 75 x 95MM	70mm

## SCRIBERS

- A comprehensive line of steel body scribers for machinists, engravers, mechanics and craftsmen.
- Basic tool for scribing and marking. Scribers can be used on metal, glass, plastics and ceramics. Scriber points are hardened 55-60 HRC. Scribers are finely tapered permitting better sighting during work.



Part No.	Code	Description	Overall Length
GZ-03210	MS/7	Double End Scriber, Steel Body, Straight & 90 Deg Point	190mm
GZ-03211	MS/H/8	Double End Scriber, Steel Body, Straight & 90 Deg Point	230mm
GZ-03214	MS/P/3	Pocket Scriber, Steel Body	89mm
GZ-03217	MSCP/6	Double End Scriber, Steel Body, Point And Chisel End	170mm
GZ-03221	MS/MG/6	Pocket Scriber, Steel Body, Carbide Tip With Magnet	150mm

## MEASURING TOOLS

### SPRING CALIPERS & DIVIDERS

- Calipers are designed for taking comparative measurements and transferring the dimensions to a micrometer, precision rule etc.
- Dividers are used for marking out circles on steel or transferring measurement from master templates.
- Manufactured from high grade steel, calipers and dividers have a spring joint for precision settings. The legs pivot on a roller and are tensioned by bow spring. The fulcrum stud has a large bearing surface that prevents side deflection of legs.
- Divider points are hardened 50-55 HRC for increased wear resistance.



Part No.	Code	Arm Length
<b>Spring Inside Calipers</b>		
GZ-01401	ID/4	100mm
GZ-01402	ID/6	150mm
GZ-01403	ID/8	200mm
GZ-01404	ID/10	250mm
GZ-01405	ID/12	300mm
<b>Spring Outside Calipers</b>		
GZ-01411	OD/4	100mm
GZ-01412	OD/6	150mm
GZ-01413	OD/8	200mm
GZ-01414	OD/10	250mm
GZ-01415	OD/12	300mm
<b>Spring Dividers</b>		
GZ-01421	DD/4	100mm
GZ-01422	DD/6	150mm
GZ-01423	DD/8	200mm
GZ-01424	DD/10	250mm
GZ-01425	DD/12	300mm

## SPRING CALIPERS & DIVIDERS - PREMIUM

- Precision made to exact standards throughout. Manufactured from high grade steel, the legs are machined to a smooth taper. Fulcrum stud has a large bearing surface preventing side deflection of legs. The finely machined solid nut runs smoothly to secure legs exactly to dimension.
- Divider points are hardened 50-55 HRC for increased wear resistance.



Spring Inside Calipers      Spring Outside Calipers      Spring Dividers

Part No.	Code	Arm Length
<b>Spring Inside Calipers with Solid Nut</b>		
GZ-01461	ID/SP/4	100mm
GZ-01462	ID/SP/6	150mm
GZ-01463	ID/SP/8	200mm
GZ-01464	ID/SP/10	250mm
GZ-01465	ID/SP/12	300mm
<b>Spring Outside Calipers with Solid Nut</b>		
GZ-01471	OD/SP/4	100mm
GZ-01472	OD/SP/6	150mm
GZ-01473	OD/SP/8	200mm
GZ-01474	OD/SP/10	250mm
GZ-01475	OD/SP/12	300mm
<b>Spring Dividers with Solid Nut</b>		
GZ-01481	DD/SP/4	100mm
GZ-01482	DD/SP/6	150mm
GZ-01483	DD/SP/8	200mm
GZ-01484	DD/SP/10	250mm
GZ-01485	DD/SP/12	300mm

### SPRING CALIPERS & DIVIDERS SETS - PREMIUM

Each set includes a spring inside caliper, spring outside caliper and a spring divider



Part No.	Code	Description
GZ-01492	CD/SP/6/ST	Spring Calipers & Dividers Sets - Premium 3 Piece, 150mm
GZ-01493	CD/SP/8/ST	Spring Calipers & Dividers Sets - Premium 3 Piece, 200mm

## DEGREE PROTRACTORS

- Manufactured from stainless steel, the Degree Protractor comes with a semi-circular or a rectangular head.
- The head has permanent deep etched graduations, 0° to 180° in opposite directions thus permitting reading an angle directly and also its supplement.
- The 150 mm blade has a graduation line on one end that permits accurate setting and reading of angles. The blade can be firmly set at the desired angle by means of a knurled nut.
- This is an ideal tool for machinists, draftsmen and mechanics for setting bevels, transferring angles, small squaring tasks, checking cutter clearances within limits etc.
- The rectangular head provides additional convenience as it incorporates 4 working edges.
- Angular Tolerance: 0.5°.

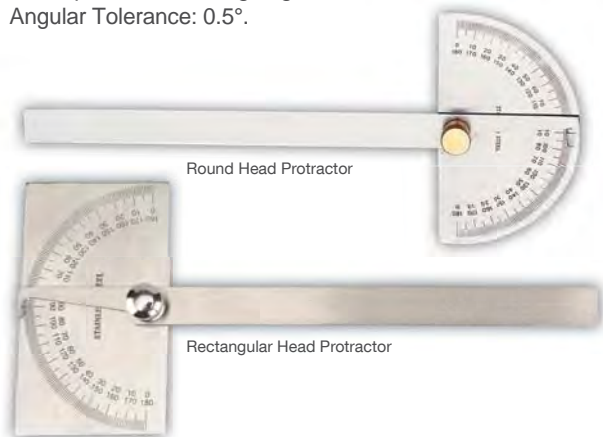

Part No.	Code	Head Shape	Blade Length
GZ-01220	DP/6	Round	150mm
GZ-01224	DP/R/6	Rectangular	150mm

## DEPTH & ANGLE GAUGE

- The ability to measure depths and angles is combined in this versatile tool.
- The head is made from high grade steel and has a black finish. It is graduated both left and right to 15°, 30°, 45° and the rule can be set to any of these angles.
- A 150mm (6") steel rule is fitted to the head and can be locked in final position by a knurled nut for depth or angular measurements.
- 150mm length



Part No.	Code	Length
GZ-01214	DG/G	Depth And Angle Gauge, 150mm