



# Core Drills

## 5% Cobalt 30mm depth

- 1 pin fits every diameter - 12mm to 50mm
- High Speed Steel with 5% Cobalt Cutters  
- Longer Lasting - Will drill harder materials
- Multi Fit - Fits all makes of magnetic based drill including all quick change systems



| Diameter | Code       | Diameter | Code       |
|----------|------------|----------|------------|
| 12       | 1905012030 | 32       | 1905032030 |
| 13       | 1905013030 | 33       | 1905033030 |
| 14       | 1905014030 | 34       | 1905034030 |
| 15       | 1905015030 | 35       | 1905035030 |
| 16       | 1905016030 | 36       | 1905036030 |
| 17       | 1905017030 | 37       | 1905037030 |
| 18       | 1905018030 | 38       | 1905038030 |
| 19       | 1905019030 | 39       | 1905039030 |
| 20       | 1905020030 | 40       | 1905040030 |
| 21       | 1905021030 | 41       | 1905041030 |
| 22       | 1905022030 | 42       | 1905042030 |
| 23       | 1905023030 | 43       | 1905043030 |
| 24       | 1905024030 | 44       | 1905044030 |
| 25       | 1905025030 | 45       | 1905045030 |
| 26       | 1905026030 | 46       | 1905046030 |
| 27       | 1905027030 | 47       | 1905047030 |
| 28       | 1905028030 | 48       | 1905048030 |
| 29       | 1905029030 | 49       | 1905049030 |
| 30       | 1905030030 | 50       | 1905050030 |
| 31       | 1905031030 |          |            |



- Use XDP 905 paste or spray for longer life

**XDP 905**



Suitable Pin RA359-B

1926500

### Stack Cutters:

HSS-Co cutters suitable for drilling multiple layers are available on request for an additional cost.

## Core Drills

# Core Drills 5% Cobalt 50mm depth



- 1 pin fits every diameter - 12mm to 60mm
- High Speed Steel with 5% Cobalt Cutters  
- Longer Lasting - Will drill harder materials
- Multi Fit - Fits all types of magnetic based drill including all quick change systems

| Diameter | Code       | Diameter | Code       |
|----------|------------|----------|------------|
| 12       | 1905012050 | 37       | 1905037050 |
| 13       | 1905013050 | 38       | 1905038050 |
| 14       | 1905014050 | 39       | 1905039050 |
| 15       | 1905015050 | 40       | 1905040050 |
| 16       | 1905016050 | 41       | 1905041050 |
| 17       | 1905017050 | 42       | 1905042050 |
| 18       | 1905018050 | 43       | 1905043050 |
| 19       | 1905019050 | 44       | 1905044050 |
| 20       | 1905020050 | 45       | 1905045050 |
| 21       | 1905021050 | 46       | 1905046050 |
| 22       | 1905022050 | 47       | 1905047050 |
| 23       | 1905023050 | 48       | 1905048050 |
| 24       | 1905024050 | 49       | 1905049050 |
| 25       | 1905025050 | 50       | 1905050050 |
| 26       | 1905026050 | 51       | 1905051050 |
| 27       | 1905027050 | 52       | 1905052050 |
| 28       | 1905028050 | 53       | 1905053050 |
| 29       | 1905029050 | 54       | 1905054050 |
| 30       | 1905030050 | 55       | 1905055050 |
| 31       | 1905031050 | 56       | 1905056050 |
| 32       | 1905032050 | 57       | 1905057050 |
| 33       | 1905033050 | 58       | 1905058050 |
| 34       | 1905034050 | 59       | 1905059050 |
| 35       | 1905035050 | 60       | 1905060050 |
| 36       | 1905036050 |          |            |

Suitable Pin RA360  
1950500





## Ejector Pins



| Description | Cutter to Suit                                       | Depth | Length | Diameter | Code    |
|-------------|--|-------|--------|----------|---------|
| RA359B      | 1901, 1902, 1905, 1908 Series                        | 25mm  | 77mm   | 6.35mm   | 1926500 |
| RA360       | 1901, 1902, 1905, 1908 Series                        | 50mm  | 102mm  | 6.35mm   | 1950500 |
| RA362       | TCT Cutter   | 50mm  | 102mm  | 8.00mm   | 2001501 |
| RA363       | TCT Cutter   | 35mm  | 87mm   | 8.00mm   | 2001500 |
| RA364       | TCT Cutter - Series 2002<br>- when using ALW adaptor | 50mm  | 117mm  | 8.00mm   | 2101500 |
| RA359C      | HSS-Co Cutter for V32 Compact                        | 25mm  | 74mm   | 6.35mm   | 1924500 |
| RA361       | HSS-Co Cutter  | 35mm  | 87mm   | 6.35mm   | 1935500 |
| RA367       | HSS-Co Cutter  | 110mm | 160mm  | 8.00mm   | 2001502 |
| RA359       | Old Series Cutters & 1905                            | 25mm  | 77mm   | 7.10mm   | 1925500 |

## HSS - 5% Cobalt Countersink with multifit

- Multi fit - suits all makes of magnetic based drills
- HSS with 5% Cobalt

| Diameter | Code  |
|----------|-------|
| 25mm     | 18533 |
| 40mm     | 18534 |
| 65mm     | 18536 |



## Core Drills Sets

- 4 cutters & 1 pin to suit
- 1 x 14, 1 x 18, 1 x 20, 1 x 22 and 1 pin
- Presented in heavy duty plastic case.
- HSS - 5% Cobalt

| Piece Set    | 5 Piece    | 5 Piece    |
|--------------|------------|------------|
| Cutter Depth | 30mm       | 50mm       |
| CODE         | 1905005030 | 1905005050 |



## Tungsten Carbide Tipped

- Suits Weldon shank drilling machines
- Alfa "Chip-Breaker System"

| CUTTER DEPTH    | 35MM DEPTH  | 50MM DEPTH  |
|-----------------|-------------|-------------|
| Cutter Diameter | 18mm - 40mm | 18mm - 50mm |

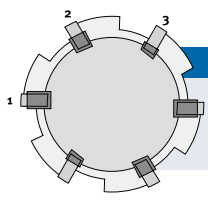

**Excision "Chip-Breaker System"**  
 1 Pre-cutter  
 2 Middle cutter  
 3 Post-cutter



## HSS - 5% Cobalt RQX 25mm depth

CUTTER DIA | 14-38MM

- Heavy duty with keyway & feather key Alfra
- Alfra "Chip-Breaker System"



## HSS - 5% Cobalt RQX 50mm depth

CUTTER DIA | 14-38MM

- Suits Weldon shank drilling machines
- HSS 5% cobalt with TiAlN coating





# Track Star Rail Core Drills

CUTTER DIA 28-38MM

- Shank to suit Track Star rail machines
- 1 pin fits every diameter
- High Speed Steel Tin coated
- 5% Cobalt for greater life



• Use XDP 905 paste see page 50

**XDP 905**

Cutting depth 25mm  
Suitable for Track Star rail machines

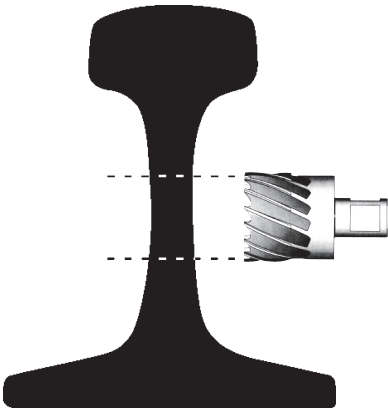

## SlimBox® DRILL SETS



- Strong, slim and compact drill sets, perfect for the workshop or toolbox
- Genuine Alpha Gold Series jobber drill bits
- Feeds and speeds chart inside every drill set



**SLIMBOX - METRIC**  
19 and 25 piece sets



**SLIMBOX - IMPERIAL**  
21 and 29 piece sets

## GOLD SERIES DRILL SETS



### 85 PIECE METRIC DRILL SET

- Genuine Alpha Gold Series jobber drills
- Handy steel carry case
- Wide selection of all popular sizes



### 100 PIECE METRIC DRILL SET

- Genuine Alpha Gold Series jobber drills
  - Handy plastic carry case
  - 1.0 - 10.0mm in 0.1mm increments

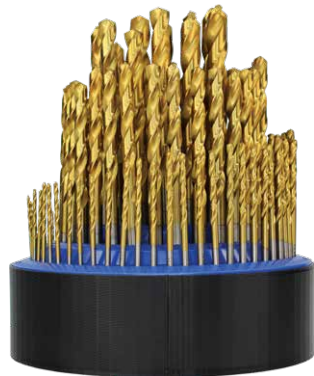

## GOLD SERIES TUFFBOX® DRILL SETS



- Tough and rugged rubber grip ABS plastic box for heavy trade use
- Strong locking latch
- Genuine Alpha Gold Series jobber drill bits
- Feeds and speeds chart inside every drill set



**25 PIECE METRIC**  
1.0 - 13.0 in 0.5mm increments



**29 PIECE IMPERIAL**  
1/16 - 1/2" in 1/64" increments

## COBALT TUFFBOX® DRILL SETS



- The premium - ideal for the widest range of materials
- Tough plastic case
- Rugged rubber grips
- Genuine Alpha 8% cobalt jobber drill bits
- Strong locking catch
- Feeds and speeds chart inside every drill set



**25 PIECE METRIC**  
1.0 - 13.0 in 0.5mm increments



**29 PIECE IMPERIAL**  
1/16 - 1/2" in 1/64" increments



## BLACK SERIES DRILLS



- Fully ground premium quality M2 HSS
- 118° split point reduces wandering
- Black oxide coating maximises lubricant hold, therefore assisting chip flow & heat dissipation
- Corrosion resistant finish
- Coolant recommended when drilling hard metals
- Available in common metric, imperial and panel/stub sizes.
- Available in: Bulk and 25 piece metric and 29 piece imperial drill sets



## SILVER SERIES DRILLS



- Fully ground premium quality M2 HSS
- 118° split point reduces wandering
- Premium bright finish
- Ideal for general purpose drilling, especially in non-ferrous metal
- Available in common metric, imperial and panel/stub sizes.
- Available in: Bulk, carded and 25 piece metric and 29 piece imperial drill sets



## TAPER SHANK DRILLS



- Premium HSS
- 118° standard point
- Tempered black oxide finish reduces friction between bit and workpiece
- Available in 5.0 - 50.0mm sizes



## BLACK SERIES TUFFBOX® DRILL SETS



- Ideal for drilling hard ferrous metals
- Tough plastic case
- Rugged rubber grips
- Genuine Alpha Black Series jobber drill bits
- Strong locking catch
- Feeds and speeds chart inside every drill set



**25 PIECE METRIC**  
1.0 - 13.0 in 0.5mm increments



**29 PIECE IMPERIAL**  
1/16 - 1/2" in 1/64" increments

## SILVER SERIES TUFFBOX® DRILL SETS



- Ideal for general purpose drilling, especially non-ferrous metal
- Tough plastic case
- Rugged rubber grips
- Genuine Alpha Silver Series jobber drill bits
- Strong locking catch
- Feeds and speeds chart inside every drill set



**25 PIECE METRIC**  
1.0 - 13.0 in 0.5mm increments



**29 PIECE IMPERIAL**  
1/16 - 1/2" in 1/64" increments

## QUICK CHANGE HSS DRILLS



- Quick change
- M2 HSS - 1/4" (6.3mm) hexagonal shank
- 135° split point
- Drills metal, wood and plastic
- Available in a 15 piece set with 1/4" quick release bit holder



## CENTRE DRILLS



- Create accurate centre holes that suit most applications
- Spotting or starting a precise hole
- 60° inclusive angle



## SPOT WELD DRILLS



- All made from cobalt HSS
- For drilling out spot welded panels
- Perfect for car bodywork panels
- Available in: Cobalt HSS, cobalt HSS titanium nitride coated, cobalt HSS dura coated and extra-long cobalt HSS



## COUNTERSINKS



- HSS cobalt countersinks
- Available in 1,3,5 flute and cross hole, in a full range of sizes.
- Precision manufactured to DIN standards
- Made in Europe



**CROSS HOLE COUNTERSINK**  
3 piece sets



**3 FLUTE COUNTERSINK**  
6 piece sets



**1 FLUTE COUNTERSINK**  
90° angle  
10.0 - 30.0mm dia



**3 FLUTE COUNTERSINK**  
90° angle  
6.3 - 40.0mm dia



**5 FLUTE COUNTERSINK**  
90° angle  
8.0 - 20.0mm dia



**CROSS HOLE COUNTERSINK**  
90° angle  
10.0 - 44.0mm dia

## STEP DRILLS



- Drill and deburr multiple size holes with the one bit
- Self-starting split point

Straight flute:

- 8 sizes available
- 7 metric and 1 imperial

Spiral flute:

- 4 sizes available
- Premium quality spiral flute for perfect clean hole cutting
- Drills materials up to 4.0mm thick

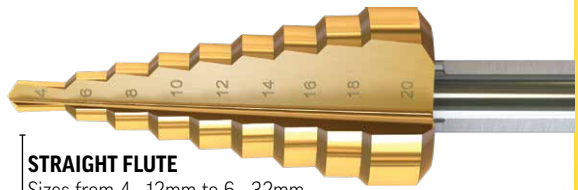

**STRAIGHT FLUTE**  
Sizes from 4 - 12mm to 6 - 32mm

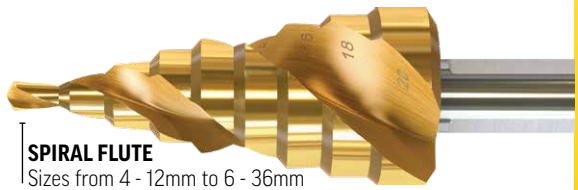

**SPIRAL FLUTE**  
Sizes from 4 - 12mm to 6 - 36mm

**NEW!** Hex Shank Step Drills now available for impact drivers. Visit [sheffield.com.au](http://sheffield.com.au)



## HAND TAPS



- Premium quality – Made in Europe to ISO and ANSI standards
- Available in carbon steel and HSS in the following ranges:
  - Metric coarse: M2 - M36
  - Metric fine: M8- M32
  - BSW: 1/8" - 1-1/2"
  - BSF: 3/16" - 1"
  - UNC: 5G - 1-1/4"
  - UNF: 5G - 1-1/4"
  - BSPF (G): 1/8" - 2"
  - NPSF: 1/8" - 1/2"
  - BSPT: 1/8" - 2"
  - NPT: 1/8" - 2"



TAPER



INTERMEDIATE



BOTTOMING

### TAP SETS

Taper, Inter and Bottoming.  
Available in most ranges and sizes.

## TAP + DIE SETS



- 42 Piece metric and imperial Sets
- Genuine Alpha taps and dies
- High carbon Japanese steel
- Precision manufactured to I.S.O. and DIN standards
- 17 different sizes
- Handy carry case



### GENERAL PURPOSE



Light industrial, motor vehicle and construction

## SDS PLUS: 2 HEAD CUT



- Made in Germany
- SDS Plus: 2 head cut available to cover all drill ranges
- 4+ high capacity and strengthened flute for superior performance

**SDS PLUS**  
Available in sizes from  
4mm to 26mm



## SDS MAX



- Made in Germany
- Secondary cutters protect the bit in the event of reinforcement collision
- Maximum energy transfer, excellent performance, long life

**SDS MAX**  
Available in sizes from  
4mm to 26mm



## CONCRETE CORING



- Fast penetration rate thanks to chisel-shaped carbide teeth
- Additional raker teeth to hollow out the entire core diameter, no chiseling out necessary
- High volume flutes for fast removal of dust and debris



**SDS-MAX CORE CUTTER**  
Available in sizes from  
40 to 80mm

## SDS CHISELS



- Premium quality chisels available in the following styles in SDS and MAX fitments:
  - Pointed chisels
  - Flat chisels
  - Spade chisels
  - Hollow chisels

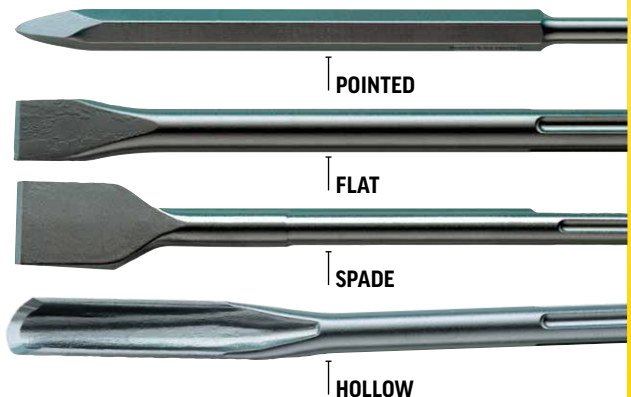

## MULTI-PURPOSE TCT



- Tungsten carbide tipped, suitable for rotary and impact drilling
- Drills metal, wood, plastic, brick, tile etc
- Available in straight shank and quick release hex shank

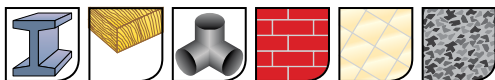

**STRAIGHT SHANK - TCT**

Available in sizes from 3.0mm to 12.0mm



**HEX SHANK - TCT IMPACT**

Available in sizes from 3.0mm to 8.0mm

## STRAIGHT SHANK MASONRY



- Tungsten carbide tipped, suitable for rotary and impact drilling
- Drills brick, tile, ceramic and concrete



**STRAIGHT SHANK - MASONRY**

Available in sizes from 3.0mm to 20.0mm

## COUNTERSINK DEPTH GAUGE DRILLS



- Drill and countersink fibre cement and compressed fibre cement sheeting



**COUNTERSINK DEPTH GAUGE - SHALLOW**

9mm deep. Available in 5.0 and 6.0mm dia



**COUNTERSINK DEPTH GAUGE - DEEP**

18mm deep. Available in 5.0 and 6.0mm dia

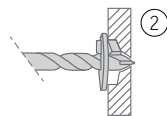
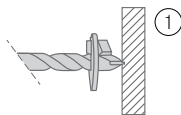

## 4 MAX - AUGER BITS

- Lasts 4x as long and cuts 4x as fast as standard spade bits
- 4 cutter head design with auger screw for efficiency
- Cutting spur for smoother clean holes
- Designed for faster chip ejection
- Hex shank for maximum grip
- 3 piece and 5 piece sets available

## SPADE BITS

- Double spur spade drills for cleaner hole cutting
- Reduced vibration and faster cutting
- 400mm OAL long series now available
- Extensions and 8 piece set available

## SHIPPER PATTERN

- HSS, Shipper type twist with cutting spur
- Suitable for all timbers
- 1/4" shank: 6mm - 12mm sizes
- 1/2" shank: 14mm - 36mm sizes





**4 MAX - AUGER BITS**  
Available in sizes from  
10mm - 32mm





**SPADE BITS**  
Available in sizes from  
6mm - 40mm





**SHIPPER PATTERN**  
Available in sizes from  
6mm - 36mm



## WOOD AUGER HEAVY DUTY

- Heavy duty nail cutting augers
- Suitable for hardwoods, power poles etc
- 7/16" quick release hex shank
- 3 extensions available for heavy duty augers
- Replaces scotch pattern auger bits



Available in  
205, 330, 457  
and 600mm  
lengths



**WOOD AUGER HEAVY DUTY**  
Available in sizes from  
10mm - 32mm



**DECKING COUNTERSINK**  
Available in sizes from  
8mm - 14mm



HSS

TCT



**DRILL AND COUNTERSINK**  
Available in sizes from  
2.0mm - 6.0mm

## DECKING COUNTERSINK

- Professional clean finish; the ultimate all-in-one, single drilling and countersink tool for timber decking
- Free-spinning stop collar with rubber o-ring protects the work surface from marks and scratches.
- Ideal for: Timber decking (hardwood & composite materials and woodworking
- Available in both TCT (2 flutes) and CRV (3 flutes)

## DRILL AND COUNTERSINK

- 1/4" quick change shank with grub screw for replacing drill
- Adjustable depth stop suitable for flush mounting and deep enough to accommodate a plug
- Available in TCT and HSS
- Drills metal, wood and plastic



### SA TYPE - CYLINDRICAL SMOOTH END

Imperial shank (1/8 & 1/4") double cut: 1/16 - 1"  
Metric shank (3 & 6mm) double cut: 1.5 - 25.4mm  
Imperial shank aluminium cut: 1/4 - 3/4"  
Metric shank aluminium cut: 6.0 - 12.7mm



### SB TYPE - CYLINDRICAL END CUT

Imperial shank (1/4") double cut: 1/8 - 3/4"  
Metric shank (6mm) double cut: 4.7 - 19mm  
Imperial shank aluminium cut: 1/4 - 3/4"  
Metric shank aluminium cut: 6.0 - 12.7mm



### SC TYPE - CYLINDRICAL BALL NOSE

Imperial shank (1/8 & 1/4") double cut: 3/32 - 1/2"  
Metric shank (3 & 6mm) double cut: 2.5 - 19mm  
Imperial shank aluminium cut: 1/4 - 3/4"  
Metric shank aluminium cut: 6.0 - 12.7mm



### SD TYPE - BALL

Imperial shank (1/8 & 1/4") double cut: 3/32 - 1"  
Metric shank (3 & 6mm) double cut: 3 - 16mm  
Imperial shank aluminium cut: 1/4 - 5/8"  
Metric shank aluminium cut: 9.5 - 12.7mm



### SE TYPE - OVAL

Imperial shank (1/8 & 1/4") double cut: 3/32 - 1"  
Metric shank (3 & 6mm) double cut: 3 - 16mm  
Imperial shank aluminium cut: 1/4 - 5/8"  
Metric shank aluminium cut: 9.5 - 12.7mm



### SF TYPE - TREE RADIUS NOSE

Imperial shank (1/8 & 1/4") double cut: 1/8 - 3/4"  
Metric shank (3 & 6mm) double cut: 6.3 - 19mm  
Imperial shank aluminium cut: 1/4 - 5/8"  
Metric shank aluminium cut: 6.0 - 9.5mm



**FULL RANGE OF BURR SETS AVAILABLE**

4, 5, 8 and 9 piece sets available

**SG TYPE - TREE POINTED NOSE**

Imperial shank (1/8 & 1/4") double cut: 1/8 - 3/4"  
Metric shank (3 & 6mm) double cut: 6.3 - 12.7mm

**SH TYPE - FLAME**

Imperial shank (1/8 & 1/4") double cut: 1/8 - 3/4"  
Metric shank (6mm) double cut: 8.0 - 19.0mm

**SL TYPE - INCLUDED ANGLE**

Imperial shank (1/8 & 1/4") double cut: 1/8 - 3/4"  
Metric shank (6mm) double cut: 6.3 - 12.7mm  
Imperial shank aluminium cut: 3/8 - 5/8"  
Metric shank aluminium cut: 12.7mm

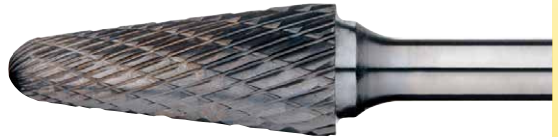
**SK TYPE - 90° CONE**

Imperial shank (1/4") single cut: 1/4 - 3/8"

**SM TYPE - POINTED CONE**

Imperial shank (1/8 & 1/4") double cut: 1/8 - 5/8"  
Metric shank (3 & 6mm) double cut: 4.3 - 16mm

**SN TYPE - INVERTED CONE**

Imperial shank (1/8 & 1/4") double cut: 1/8 - 5/8"  
Metric shank (6mm) double cut: 6.0mm

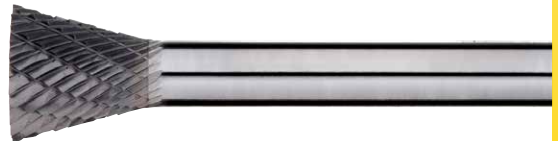

6" long series burrs also available in a large range of styles and sizes  
Visit [sheffield.com.au](http://sheffield.com.au) to view the full range

## STANDARD DRIVER BITS



We stock the highest quality driver bits - with superior head design, greater magnetism and optimum hardness. They show less wear, have a longer service life, experience less cam-out and provide overall improved operation and economic benefits. Standard, ribbed head and hi-torque designs.

- Full range of security bits available:
- Range available:

- Phillips®
- Pozi®
- Slotted
- Square
- Magnetic bit holders
- Nutsetters

### HIGH PERFORMANCE

Regular impact & torsion capacity

FULL BODY HARDNESS



High torque capacity

Superior magnetism helps the bit grip the screw and prevent cam-out

Optimum full body hardness for longer service life and less wear

### 30% MORE TORQUE\*

Maximum impact & torque capacity

DUAL TORSION ZONE

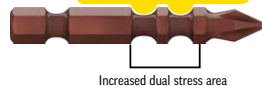

Range available:

- Phillips®
- Pozi®
- Square
- Hex

## MAXDRIVE TORSION BITS



- The MaxDrive torsion bits absorb stress in their specially engineered "dual torsion zone"
- Their specially formulated coating relieves pressure on the tip of the driver bit, giving greater durability and less breakage
- MaxDrive torsion bits are ideally suited to impact driving - and will give exceptional performance with standard usage











Huge range of Alpha driver bits available - visit [sheffield.com.au](http://sheffield.com.au)

## THUNDER ZONE IMPACT BITS

**10x LIFE**



- Thunder Zone impact driver bits with their patented spiral impact zone to absorb torsion - these driver bits are perfect for the toughest impact driving jobs
- Premium quality S2 raw material
- Range available:

- Phillips  
- Pozzi  
- Slotted  
- Square  
- Hex  

- Magnetic bit holders and adaptors

- Nutsetters 

All bits are magnetised - helps the bit grip the screw and prevent cam-out

Compression forged tip - for an ideal fit and to reduce breakage

Patented spiral impact zone - to distribute torque evenly

Full body hardness - for a longer service life

Premium quality S2 raw material



**10 x LIFE\***  
High impact & torque capacity

**SPIRAL IMPACT ZONE**

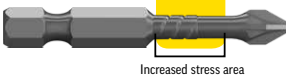

Increased stress area

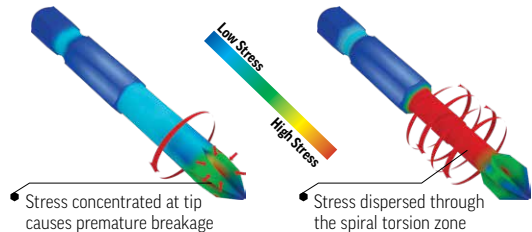

• Stress concentrated at tip causes premature breakage

• Stress dispersed through the spiral torsion zone

## HANDIPACKS



- A wide range of Alpha driver bits are now available packed in our premium handipack reusable packaging - keep your driver bits safe at all times!



## JOBBER DRILLS - CARDED METRIC HIGH SPEED STEEL

M2 High Speed Steel

- Premium HSS M2 material to provide long life in demanding professional applications

Split point

- Starts drilling on contact
- No "walking" or "skating" on drilling surface
- No centre punch required

118° Point Angle

- Suitable for heavy-duty drilling in metal, wood and plastic



## JOBBER DRILLS - CARDED IMPERIAL HIGH SPEED STEEL

M2 High Speed Steel

- Premium HSS M2 material to provide long life in demanding professional applications

Split point

- Starts drilling on contact
- No "walking" or "skating" on drilling surface
- No centre punch required

118° Point Angle

- Suitable for heavy-duty drilling in metal, wood and plastic



| Part No.  | Diameter | Flute Length | Overall Length | Qty Per Pack |
|-----------|----------|--------------|----------------|--------------|
| UN304-010 | 1mm      | 12mm         | 34mm           | 2            |
| UN304-015 | 1.5mm    | 18mm         | 40mm           | 2            |
| UN304-020 | 2mm      | 24mm         | 49mm           | 2            |
| UN304-025 | 2.5mm    | 30mm         | 57mm           | 2            |
| UN304-030 | 3mm      | 33mm         | 61mm           | 2            |
| UN304-035 | 3.5mm    | 39mm         | 70mm           | 1            |
| UN304-040 | 4mm      | 43mm         | 75mm           | 1            |
| UN304-045 | 4.5mm    | 47mm         | 80mm           | 1            |
| UN304-050 | 5mm      | 52mm         | 86mm           | 1            |
| UN304-055 | 5.5mm    | 57mm         | 93mm           | 1            |
| UN304-060 | 6mm      | 57mm         | 93mm           | 1            |
| UN304-065 | 6.5mm    | 63mm         | 101mm          | 1            |
| UN304-070 | 7mm      | 69mm         | 109mm          | 1            |
| UN304-075 | 7.5mm    | 69mm         | 109mm          | 1            |
| UN304-080 | 8mm      | 75mm         | 117mm          | 1            |
| UN304-085 | 8.5mm    | 75mm         | 117mm          | 1            |
| UN304-090 | 9mm      | 81mm         | 125mm          | 1            |
| UN304-095 | 9.5mm    | 81mm         | 125mm          | 1            |
| UN304-100 | 10mm     | 87mm         | 133mm          | 1            |
| UN304-105 | 10.5mm   | 87mm         | 133mm          | 1            |
| UN304-110 | 11mm     | 94mm         | 142mm          | 1            |
| UN304-115 | 11.5mm   | 94mm         | 142mm          | 1            |
| UN304-120 | 12mm     | 101mm        | 151mm          | 1            |
| UN304-125 | 12.5mm   | 101mm        | 151mm          | 1            |
| UN304-130 | 13mm     | 101mm        | 151mm          | 1            |

| Part No.  | Diameter | Flute Length | Overall Length | Qty Per Pack |
|-----------|----------|--------------|----------------|--------------|
| UN306-062 | 1/16"    | 22mm         | 48mm           | 2            |
| UN306-078 | 5/64"    | 25mm         | 51mm           | 2            |
| UN306-093 | 3/32"    | 32mm         | 57mm           | 2            |
| UN306-109 | 7/64"    | 38mm         | 67mm           | 2            |
| UN306-125 | 1/8"     | 41mm         | 70mm           | 2            |
| UN306-140 | 9/64"    | 44mm         | 73mm           | 1            |
| UN306-156 | 5/32"    | 51mm         | 79mm           | 1            |
| UN306-171 | 11/64"   | 54mm         | 83mm           | 1            |
| UN306-187 | 3/16"    | 59mm         | 89mm           | 1            |
| UN306-203 | 13/64"   | 62mm         | 92mm           | 1            |
| UN306-218 | 7/32"    | 64mm         | 95mm           | 1            |
| UN306-234 | 15/64"   | 67mm         | 98mm           | 1            |
| UN306-250 | 1/4"     | 70mm         | 102mm          | 1            |
| UN306-265 | 17/64"   | 73mm         | 105mm          | 1            |
| UN306-281 | 9/32"    | 75mm         | 108mm          | 1            |
| UN306-296 | 19/64"   | 78mm         | 111mm          | 1            |
| UN306-312 | 5/16"    | 81mm         | 114mm          | 1            |
| UN306-328 | 21/64"   | 84mm         | 117mm          | 1            |
| UN306-343 | 11/32"   | 87mm         | 121mm          | 1            |
| UN306-359 | 23/64"   | 89mm         | 124mm          | 1            |
| UN306-375 | 3/8"     | 92mm         | 127mm          | 1            |
| UN306-390 | 25/64"   | 95mm         | 130mm          | 1            |
| UN306-406 | 13/32"   | 98mm         | 133mm          | 1            |
| UN306-421 | 27/64"   | 100mm        | 137mm          | 1            |
| UN306-437 | 7/16"    | 103mm        | 140mm          | 1            |
| UN306-453 | 29/64"   | 106mm        | 143mm          | 1            |
| UN306-468 | 15/32"   | 110mm        | 146mm          | 1            |
| UN306-484 | 31/64"   | 111mm        | 149mm          | 1            |
| UN306-500 | 1/2"     | 114mm        | 152mm          | 1            |

## JOBBER DRILLS - BULK METRIC HIGH SPEED STEEL

M2 High Speed Steel

- Premium HSS M2 material to provide long life in demanding professional applications

Split point

- Starts drilling on contact
- No "walking" or "skating" on drilling surface
- No centre punch required

118° Point Angle

- Suitable for heavy-duty drilling in metal, wood and plastic



| Part No.  | Diameter | Flute Length | Overall Length | Qty Per Pack |
|-----------|----------|--------------|----------------|--------------|
| UN300-010 | 1mm      | 12mm         | 34mm           | 10           |
| UN300-015 | 1.5mm    | 18mm         | 40mm           | 10           |
| UN300-020 | 2mm      | 24mm         | 49mm           | 10           |
| UN300-025 | 2.5mm    | 30mm         | 57mm           | 10           |
| UN300-030 | 3mm      | 33mm         | 61mm           | 10           |
| UN300-035 | 3.5mm    | 39mm         | 70mm           | 10           |
| UN300-040 | 4mm      | 43mm         | 75mm           | 10           |
| UN300-045 | 4.5mm    | 47mm         | 80mm           | 10           |
| UN300-050 | 5mm      | 52mm         | 86mm           | 10           |
| UN300-055 | 5.5mm    | 57mm         | 93mm           | 10           |
| UN300-058 | 5.8mm    | 57mm         | 93mm           | 10           |
| UN300-060 | 6mm      | 63mm         | 101mm          | 10           |
| UN300-065 | 6.5mm    | 69mm         | 109mm          | 10           |
| UN300-070 | 7mm      | 69mm         | 109mm          | 10           |
| UN300-075 | 7.5mm    | 75mm         | 117mm          | 10           |
| UN300-080 | 8mm      | 75mm         | 117mm          | 5            |
| UN300-085 | 8.5mm    | 81mm         | 125mm          | 5            |
| UN300-090 | 9mm      | 81mm         | 125mm          | 5            |
| UN300-095 | 9.5mm    | 87mm         | 133mm          | 5            |
| UN300-100 | 10mm     | 87mm         | 133mm          | 5            |
| UN300-105 | 10.5mm   | 94mm         | 142mm          | 5            |
| UN300-110 | 11mm     | 94mm         | 142mm          | 5            |
| UN300-115 | 11.5mm   | 94mm         | 142mm          | 5            |
| UN300-120 | 12mm     | 101mm        | 151mm          | 5            |
| UN300-125 | 12.5mm   | 101mm        | 151mm          | 5            |
| UN300-130 | 13mm     | 101mm        | 151mm          | 5            |

## JOBBER DRILLS - BULK IMPERIAL HIGH SPEED STEEL

M2 High Speed Steel

- Premium HSS M2 material to provide long life in demanding professional applications

Split point

- Starts drilling on contact
- No "walking" or "skating" on drilling surface
- No centre punch required

118° Point Angle

- Suitable for heavy-duty drilling in metal, wood and plastic



| Part No.  | Diameter | Flute Length | Overall Length | Qty Per Pack |
|-----------|----------|--------------|----------------|--------------|
| UN302-062 | 1/16"    | 22mm         | 48mm           | 10           |
| UN302-078 | 5/64"    | 25mm         | 51mm           | 10           |
| UN302-093 | 3/32"    | 32mm         | 57mm           | 10           |
| UN302-109 | 7/64"    | 38mm         | 67mm           | 10           |
| UN302-125 | 1/8"     | 41mm         | 70mm           | 10           |
| UN302-140 | 9/64"    | 44mm         | 73mm           | 10           |
| UN302-156 | 5/32"    | 51mm         | 79mm           | 10           |
| UN302-171 | 11/64"   | 54mm         | 83mm           | 10           |
| UN302-187 | 3/16"    | 59mm         | 89mm           | 10           |
| UN302-203 | 13/64"   | 62mm         | 92mm           | 10           |
| UN302-218 | 7/32"    | 64mm         | 95mm           | 10           |
| UN302-234 | 15/64"   | 67mm         | 98mm           | 10           |
| UN302-250 | 1/4"     | 70mm         | 102mm          | 10           |
| UN302-265 | 17/64"   | 73mm         | 105mm          | 10           |
| UN302-281 | 9/32"    | 75mm         | 108mm          | 10           |
| UN302-296 | 19/64"   | 78mm         | 111mm          | 10           |
| UN302-312 | 5/16"    | 81mm         | 114mm          | 5            |
| UN302-328 | 21/64"   | 84mm         | 117mm          | 5            |
| UN302-343 | 11/32"   | 87mm         | 121mm          | 5            |
| UN302-359 | 23/64"   | 89mm         | 124mm          | 5            |
| UN302-375 | 3/8"     | 92mm         | 127mm          | 5            |
| UN302-390 | 25/64"   | 95mm         | 130mm          | 5            |
| UN302-406 | 13/32"   | 98mm         | 133mm          | 5            |
| UN302-421 | 27/64"   | 100mm        | 137mm          | 5            |
| UN302-437 | 7/16"    | 103mm        | 140mm          | 5            |
| UN302-453 | 29/64"   | 106mm        | 143mm          | 5            |
| UN302-468 | 15/32"   | 110mm        | 146mm          | 5            |
| UN302-484 | 31/64"   | 111mm        | 149mm          | 5            |
| UN302-500 | 1/2"     | 114mm        | 152mm          | 5            |

## JOBBER DRILL SETS METRIC HIGH SPEED STEEL



**PART NO. UN308-110** | 19 PIECE METRIC SET 1.0mm - 10.0mm

| Part No.  | Diameter | Part No.  | Diameter |
|-----------|----------|-----------|----------|
| UN304-010 | 1mm      | UN304-060 | 6mm      |
| UN304-015 | 1.5mm    | UN304-065 | 6.5mm    |
| UN304-020 | 2mm      | UN304-070 | 7mm      |
| UN304-025 | 2.5mm    | UN304-075 | 7.5mm    |
| UN304-030 | 3mm      | UN304-080 | 8mm      |
| UN304-035 | 3.5mm    | UN304-085 | 8.5mm    |
| UN304-040 | 4mm      | UN304-090 | 9mm      |
| UN304-045 | 4.5mm    | UN304-095 | 9.5mm    |
| UN304-050 | 5mm      | UN304-100 | 10mm     |
| UN304-055 | 5.5mm    |           |          |

## JOBBER DRILL SETS IMPERIAL HIGH SPEED STEEL



**PART NO. UN308-340** | 21 PIECE IMPERIAL SET 1/16" - 3/8"

| Part No.  | Diameter | Part No.  | Diameter |
|-----------|----------|-----------|----------|
| UN306-062 | 1/16"    | UN306-234 | 15/64"   |
| UN306-078 | 5/64"    | UN306-250 | 1/4"     |
| UN306-093 | 3/32"    | UN306-265 | 17/64"   |
| UN306-109 | 7/64"    | UN306-281 | 9/32"    |
| UN306-125 | 1/8"     | UN306-296 | 19/64"   |
| UN306-140 | 9/64"    | UN306-312 | 5/16"    |
| UN306-156 | 5/32"    | UN306-328 | 21/64"   |
| UN306-171 | 11/64"   | UN306-343 | 11/32"   |
| UN306-187 | 3/16"    | UN306-359 | 23/64"   |
| UN306-203 | 13/64"   | UN306-375 | 3/8"     |
| UN306-218 | 7/32"    |           |          |



**PART NO. UN308-120** | 25 PIECE METRIC SET 1.0mm - 13.0mm

| Part No.  | Diameter | Part No.  | Diameter |
|-----------|----------|-----------|----------|
| UN304-010 | 1mm      | UN304-075 | 7.5mm    |
| UN304-015 | 1.5mm    | UN304-080 | 8mm      |
| UN304-020 | 2mm      | UN304-085 | 8.5mm    |
| UN304-025 | 2.5mm    | UN304-090 | 9mm      |
| UN304-030 | 3mm      | UN304-095 | 9.5mm    |
| UN304-035 | 3.5mm    | UN304-100 | 10mm     |
| UN304-040 | 4mm      | UN304-105 | 10.5mm   |
| UN304-045 | 4.5mm    | UN304-110 | 11mm     |
| UN304-050 | 5mm      | UN304-115 | 11.5mm   |
| UN304-055 | 5.5mm    | UN304-120 | 12mm     |
| UN304-060 | 6mm      | UN304-125 | 12.5mm   |
| UN304-065 | 6.5mm    | UN304-130 | 13mm     |
| UN304-070 | 7mm      |           |          |



**PART NO. UN308-360** | 29 PIECE IMPERIAL SET 1/16" - 1/2"

| Part No.  | Diameter | Part No.  | Diameter |
|-----------|----------|-----------|----------|
| UN306-062 | 1/16"    | UN306-296 | 19/64"   |
| UN306-078 | 5/64"    | UN306-312 | 5/16"    |
| UN306-093 | 3/32"    | UN306-328 | 21/64"   |
| UN306-109 | 7/64"    | UN306-343 | 11/32"   |
| UN306-125 | 1/8"     | UN306-359 | 23/64"   |
| UN306-140 | 9/64"    | UN306-375 | 3/8"     |
| UN306-156 | 5/32"    | UN306-390 | 5/64"    |
| UN306-171 | 11/64"   | UN306-406 | 13/32"   |
| UN306-187 | 3/16"    | UN306-421 | 27/64"   |
| UN306-203 | 13/64"   | UN306-437 | 7/16"    |
| UN306-218 | 7/32"    | UN306-453 | 29/64"   |
| UN306-234 | 15/64"   | UN306-468 | 15/32"   |
| UN306-250 | 1/4"     | UN306-484 | 31/64"   |
| UN306-265 | 17/64"   | UN306-500 | 1/2"     |
| UN306-281 | 9/32"    |           |          |



# JOBBER DRILL SETS

## METRIC HIGH SPEED STEEL

### M2 High Speed Steel

- Premium HSS M2 material to provide long life in demanding professional applications

### Split point

- Starts drilling on contact
- No "walking" or "skating" on drilling surface
- No centre punch required



**PART NO. UN308-020 | 25 PIECE METRIC SET 1.0mm - 13.0mm**

| Part No.  | Diameter | Part No.  | Diameter |
|-----------|----------|-----------|----------|
| UN304-010 | 1mm      | UN304-075 | 7.5mm    |
| UN304-015 | 1.5mm    | UN304-080 | 8mm      |
| UN304-020 | 2mm      | UN304-085 | 8.5mm    |
| UN304-025 | 2.5mm    | UN304-090 | 9mm      |
| UN304-030 | 3mm      | UN304-095 | 9.5mm    |
| UN304-035 | 3.5mm    | UN304-100 | 10mm     |
| UN304-040 | 4mm      | UN304-105 | 10.5mm   |
| UN304-045 | 4.5mm    | UN304-110 | 11mm     |
| UN304-050 | 5mm      | UN304-115 | 11.5mm   |
| UN304-055 | 5.5mm    | UN304-120 | 12mm     |
| UN304-060 | 6mm      | UN304-125 | 12.5mm   |
| UN304-065 | 6.5mm    | UN304-130 | 13mm     |
| UN304-070 | 7mm      |           |          |

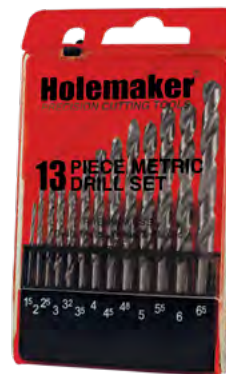

**PART NO. UN308-008 | 13PIECE METRIC SET 1.5mm - 6.5mm**

| Part No.  | Diameter | Part No.  | Diameter |
|-----------|----------|-----------|----------|
| UN304-015 | 1.5mm    | UN304-050 | 4.5mm    |
| UN304-020 | 2mm      | UN304-055 | 4.8mm    |
| UN304-025 | 2.5mm    | UN304-060 | 5mm      |
| UN304-030 | 3mm      | UN304-065 | 5.5mm    |
| UN304-035 | 3.2mm    | UN304-065 | 6mm      |
| UN304-040 | 3.5mm    | UN304-070 | 6.5mm    |
| UN304-045 | 4mm      |           |          |



**PART NO. UN308-010 | 19 PIECE METRIC SET 1.0mm - 10.0mm**

| Part No.  | Diameter | Part No.  | Diameter |
|-----------|----------|-----------|----------|
| UN304-010 | 1mm      | UN304-060 | 6mm      |
| UN304-015 | 1.5mm    | UN304-065 | 6.5mm    |
| UN304-020 | 2mm      | UN304-070 | 7mm      |
| UN304-025 | 2.5mm    | UN304-075 | 7.5mm    |
| UN304-030 | 3mm      | UN304-080 | 8mm      |
| UN304-035 | 3.5mm    | UN304-085 | 8.5mm    |
| UN304-040 | 4mm      | UN304-090 | 9mm      |
| UN304-045 | 4.5mm    | UN304-095 | 9.5mm    |
| UN304-050 | 5mm      | UN304-100 | 10mm     |
| UN304-055 | 5.5mm    |           |          |

## STEP DRILLS

### SPIRAL FLUTE STEP DRILLS

The Titanium Nitride coating significantly increases the tool life by providing the following benefits:

- Increased surface hardness to 85HRC
- Ceramic surface, reducing friction by up to 30%
- Especially resistant to cold welding
- Suitable for cutting a wide range of materials



| Part No.          | Sizes Included  | Step Length | Over All Length | Shank Diameter |
|-------------------|---|-------------|-----------------|----------------|
| <b>SD4-20MM</b>   | 4, 6, 8, 10, 12, 14, 16, 18, 20mm   | 3.0mm       | 74.5mm          | 8mm            |
| <b>SD5-25MM</b>   | 5, 7, 9, 11, 13, 15, 17, 19, 21, 23, 25mm                                   | 3.0mm       | 83.0mm          | 10mm           |
| <b>SD6-30MM</b>   | 6, 8, 10, 12, 14, 16, 18, 20, 22, 24, 26, 28, 30mm                          | 3.0mm       | 98.0mm          | 12mm           |
| <b>SD7-40.5MM</b> | 7, 10.5, 12.5, 14.5, 16.5, 18.5, 20.5, 23.5, 25.5, 30.5, 32.5, 38.5, 40.5mm | 3.0mm       | 115mm           | 12mm           |

### SPIRAL FLUTE STEP DRILLS LONG STEP



| Part No.         | Sizes Included                                 | Step Length | Over All Length | Shank Diameter |
|------------------|--|-------------|-----------------|----------------|
| <b>SDL4-12MM</b> | 4, 5, 6, 7, 8, 9, 10, 11, 12mm                 | 5.5mm       | 63.6mm          | 8mm            |
| <b>SDL6-38MM</b> | 6, 9, 13, 16, 19, 21, 23, 26, 29, 32, 35, 38mm | 5.5mm       | 101mm           | 12mm           |

### SPIRAL FLUTE STEP DRILLS EXTRA LONG STEP



| Part No.          | Sizes Included    | Step Length | Over All Length | Shank Diameter |
|-------------------|-------------------|-------------|-----------------|----------------|
| <b>SDXL4-12MM</b> | 4, 6, 8, 10, 12mm | 8.0mm       | 64.0mm          | 8mm            |

### STRAIGHT FLUTE STEP DRILLS



| Part No.          | Sizes Included                                     | Step Length | Over All Length | Shank Diameter |
|-------------------|--|-------------|-----------------|----------------|
| <b>SDST4-12MM</b> | 4, 5, 6, 7, 8, 9, 10, 11, 12mm                     | 3.75mm      | 65.5mm          | 8mm            |
| <b>SDST4-20MM</b> | 4, 6, 8, 10, 12, 14, 16, 18, 20mm                  | 4.0mm       | 75.0mm          | 8mm            |
| <b>SDST5-25MM</b> | 5, 7, 9, 11, 13, 15, 17, 19, 21, 23, 25mm          | 4.0mm       | 81.8mm          | 10mm           |
| <b>SDST6-30MM</b> | 6, 8, 10, 12, 14, 16, 18, 20, 22, 24, 26, 28, 30mm | 3.75mm      | 97.0mm          | 12mm           |



### SPIRAL FLUTE STEP DRILL SET

#### PART NO. SDSET-1 | SET CONTENTS

| Quantity | Part No.        | Size min-max |
|----------|-----------------|--------------|
| 1        | <b>SD4-20MM</b> | 4 - 20mm     |
| 1        | <b>SD5-25MM</b> | 5 - 25mm     |
| 1        | <b>SD6-30MM</b> | 6 - 30mm     |

### STRAIGHT FLUTE STEP DRILL SET

#### PART NO. SDSTSET-1 | SET CONTENTS

| Quantity | Part No.          | Size min-max |
|----------|-------------------|--------------|
| 1        | <b>SDST4-12MM</b> | 4 - 12mm     |
| 1        | <b>SDST5-25MM</b> | 5 - 25mm     |
| 1        | <b>SDST6-30MM</b> | 6 - 30mm     |

## COUNTERSINKS

### COUNTERSINKS CROSS HOLE HIGH SPEED STEEL



| Part No. | Size      | Angle | Shank Diameter |
|----------|-----------|-------|----------------|
| SWCS-5   | 2 - 5mm   | 90°   | 6mm            |
| SWCS-10  | 5 - 10mm  | 90°   | 8mm            |
| SWCS-15  | 10 - 15mm | 90°   | 10mm           |
| SWCS-20  | 15 - 20mm | 90°   | 12mm           |
| SWCS-25  | 20 - 25mm | 90°   | 12mm           |



### CROSS HOLE COUNTERSINK SET

#### PART NO. SWSET-05 | SET CONTENTS

| Quantity | Size min-max |
|----------|--------------|
| 1        | 2 - 5mm      |
| 1        | 5 - 10mm     |
| 1        | 10 - 15mm    |
| 1        | 15 - 20mm    |
| 1        | 20 - 25mm    |

### COUNTERSINKS 3 FLUTE HIGH SPEED STEEL



| Part No. | Size min-max | Angle | Shank Diameter |
|----------|--------------|-------|----------------|
| STCS-06  | 3 - 6.4mm    | 90°   | 5mm            |
| STCS-08  | 3 - 8.4mm    | 90°   | 6mm            |
| STCS-10  | 3 - 10.4mm   | 90°   | 6mm            |
| STCS-12  | 3 - 12.4mm   | 90°   | 8mm            |
| STCS-16  | 3 - 16.5mm   | 90°   | 10mm           |
| STCS-20  | 3 - 20.5mm   | 90°   | 10mm           |
| STCS-25  | 3 - 25mm     | 90°   | 10mm           |
| STCS-31  | 3 - 31mm     | 90°   | 12mm           |
| STCS-40  | 3 - 40mm     | 90°   | 15mm           |



STSET-03

### 3 FLUTE COUNTERSINK SETS

#### PART NO. STSET-01 | SET CONTENTS

| Quantity | Size min-max |
|----------|--------------|
| 1        | 3 - 6.4mm    |
| 1        | 3 - 8.4mm    |
| 1        | 3 - 10.4mm   |
| 1        | 3 - 12.4mm   |
| 1        | 3 - 16.5mm   |
| 1        | 3 - 20.5mm   |

#### PART NO. STSET-03 | SET CONTENTS

| Quantity | Size min-max |
|----------|--------------|
| 1        | 3 - 10.4mm   |
| 1        | 3 - 16.5mm   |
| 1        | 3 - 25mm     |



#### PART NO. STSET-05 | SET CONTENTS

| Quantity | Size min-max |
|----------|--------------|
| 1        | 3 - 8.4mm    |
| 1        | 3 - 12.4mm   |
| 1        | 3 - 20.5mm   |



## CARBIDE BURRS DOUBLE CUT

### CYLINDRICAL - SQUARE END



| Part No. | Head Diameter | Flute Length | Over All Length | Shank Diameter | Style |
|----------|---------------|--------------|-----------------|----------------|-------|
| CB-SA43  | 1/8"          | 9/16"        | 1-1/2"          | 1/8"           | SA-43 |
| CB-SA51  | 1/4"          | 1/2"         | 1-1/2"          | 1/8"           | SA-51 |
| CB-SA14  | 3/16"         | 5/8"         | 2"              | 1/4"           | SA-14 |
| CB-SA1   | 1/4"          | 5/8"         | 2"              | 1/4"           | SA-1  |
| CB-SA2   | 5/16"         | 3/4"         | 2-1/2"          | 1/4"           | SA-2  |
| CB-SA3   | 3/8"          | 3/4"         | 2-1/2"          | 1/4"           | SA-3  |
| CB-SA4   | 7/16"         | 1"           | 2-3/4"          | 1/4"           | SA-4  |
| CB-SA5   | 1/2"          | 1"           | 2-3/4"          | 1/4"           | SA-5  |
| CB-SA6   | 5/8"          | 1"           | 2-3/4"          | 1/4"           | SA-6  |
| CB-SA7   | 3/4"          | 1"           | 2-3/4"          | 1/4"           | SA-7  |
| CB-SA9   | 1"            | 1"           | 2-3/4"          | 1/4"           | SA-9  |

### CYLINDRICAL - END CUT



| Part No. | Head Diameter | Flute Length | Over All Length | Shank Diameter | Style |
|----------|---------------|--------------|-----------------|----------------|-------|
| CB-SB43  | 1/8"          | 9/16"        | 1-1/2"          | 1/8"           | SB-43 |
| CB-SB1   | 1/4"          | 5/8"         | 2"              | 1/4"           | SB-1  |
| CB-SB2   | 5/16"         | 3/4"         | 2-1/2"          | 1/4"           | SB-2  |
| CB-SB3   | 3/8"          | 3/4"         | 2-1/2"          | 1/4"           | SB-3  |
| CB-SB4   | 7/16"         | 1"           | 2-3/4"          | 1/4"           | SB-4  |
| CB-SB5   | 1/2"          | 1"           | 2-3/4"          | 1/4"           | SB-5  |
| CB-SB6   | 5/8"          | 1"           | 2-3/4"          | 1/4"           | SB-6  |
| CB-SB7   | 3/4"          | 1"           | 2-3/4"          | 1/4"           | SB-7  |
| CB-SB9   | 1"            | 1"           | 2-3/4"          | 1/4"           | SB-9  |

### CYLINDRICAL - RADIUS END



| Part No. | Head Diameter | Flute Length | Over All Length | Shank Diameter | Style |
|----------|---------------|--------------|-----------------|----------------|-------|
| CB-SC42  | 1/8"          | 9/16"        | 1-1/2"          | 1/8"           | SC-42 |
| CB-SC53  | 3/16"         | 1/2"         | 1-1/2"          | 1/8"           | SC-53 |
| CB-SC51  | 1/4"          | 1/2"         | 1-3/4"          | 1/8"           | SC-51 |
| CB-SC1   | 1/4"          | 5/8"         | 2"              | 1/4"           | SC-1  |
| CB-SC2   | 5/16"         | 3/4"         | 2-1/2"          | 1/4"           | SC-2  |
| CB-SC3   | 3/8"          | 3/4"         | 2-1/2"          | 1/4"           | SC-3  |
| CB-SC4   | 7/16"         | 1"           | 2-3/4"          | 1/4"           | SC-4  |
| CB-SC5   | 1/2"          | 1"           | 2-3/4"          | 1/4"           | SC-5  |
| CB-SC6   | 5/8"          | 1"           | 2-3/4"          | 1/4"           | SC-6  |
| CB-SC7   | 3/4"          | 1"           | 2-3/4"          | 1/4"           | SC-7  |

### BALL SHAPE



| Part No. | Head Diameter | Flute Length | Over All Length | Shank Diameter | Style |
|----------|---------------|--------------|-----------------|----------------|-------|
| CB-SD42  | 1/8"          | -            | 1-1/2"          | 1/8"           | SD-42 |
| CB-SD51  | 1/4"          | -            | 2"              | 1/8"           | SD-51 |
| CB-SD1   | 1/4"          | -            | 2"              | 1/4"           | SD-1  |
| CB-SD2   | 5/16"         | -            | 2-1/16"         | 1/4"           | SD-2  |
| CB-SD3   | 3/8"          | -            | 2-1/16"         | 1/4"           | SD-3  |
| CB-SD4   | 7/16"         | -            | 2-1/8"          | 1/4"           | SD-4  |
| CB-SD5   | 1/2"          | -            | 2-3/16"         | 1/4"           | SD-5  |
| CB-SD6   | 5/8"          | -            | 2-5/16"         | 1/4"           | SD-6  |
| CB-SD7   | 3/4"          | -            | 2-7/16"         | 1/4"           | SD-7  |
| CB-SD9   | 1"            | -            | 2-3/4"          | 1/4"           | SD-9  |

### OVAL SHAPE



| Part No. | Head Diameter | Flute Length | Over All Length | Shank Diameter | Style |
|----------|---------------|--------------|-----------------|----------------|-------|
| CB-SE41  | 1/8"          | 7/32"        | 1-1/2"          | 1/8"           | SE-41 |
| CB-SE1   | 1/4"          | 3/8"         | 2"              | 1/4"           | SE-1  |
| CB-SE3   | 3/8"          | 5/8"         | 2-3/8"          | 1/4"           | SE-3  |
| CB-SE5   | 1/2"          | 7/8"         | 2-5/8"          | 1/4"           | SE-5  |
| CB-SE6   | 5/8"          | 1"           | 2-3/4"          | 1/4"           | SE-6  |
| CB-SE7   | 3/4"          | 1"           | 2-3/4"          | 1/4"           | SE-7  |

## TREE SHAPE - RADIUS END



| Part No. | Head Diameter | Flute Length | Over All Length | Shank Diameter | Style |
|----------|---------------|--------------|-----------------|----------------|-------|
| CB-SF42  | 1/8"          | 1/2"         | 1-1/2"          | 1/8"           | SF-42 |
| CB-SF51  | 1/4"          | 1/2"         | 1-3/4"          | 1/8"           | SF-51 |
| CB-SF1   | 1/4"          | 3/4"         | 2"              | 1/4"           | SF-1  |
| CB-SF3   | 3/8"          | 3/4"         | 2-1/2"          | 1/4"           | SF-3  |
| CB-SF4   | 7/16"         | 1"           | 2-3/4"          | 1/4"           | SF-4  |
| CB-SF5   | 1/2"          | 1"           | 2-3/4"          | 1/4"           | SF-5  |
| CB-SF6   | 5/8"          | 1"           | 2-3/4"          | 1/4"           | SF-6  |
| CB-SF7   | 3/4"          | 1"           | 2-3/4"          | 1/4"           | SF-7  |

## TAPERED - RADIUS END



| Part No. | Head Diameter | Flute Length | Over All Length | Shank Diameter | Angle | Style |
|----------|---------------|--------------|-----------------|----------------|-------|-------|
| CB-SL42  | 1/8"          | 1/2"         | 1-1/2"          | 1/8"           | 7°    | SL-42 |
| CB-SL1   | 1/4"          | 5/8"         | 2"              | 1/4"           | 14°   | SL-1  |
| CB-SL2   | 5/16"         | 7/8"         | 2-5/8"          | 1/4"           | 14°   | SL-2  |
| CB-SL3   | 3/8"          | 1-1/16"      | 2-13/16"        | 1/4"           | 14°   | SL-3  |
| CB-SL4   | 1/2"          | 1-1/8"       | 2-7/8"          | 1/4"           | 14°   | SL-4  |
| CB-SL6   | 5/8"          | 1-5/16"      | 3-1/16"         | 1/4"           | 14°   | SL-6  |
| CB-SL7   | 3/4"          | 1-1/2"       | 3-1/4"          | 1/4"           | 14°   | SL-7  |

## TREE SHAPE - POINTED END



| Part No. | Head Diameter | Flute Length | Over All Length | Shank Diameter | Style |
|----------|---------------|--------------|-----------------|----------------|-------|
| CB-SG43  | 1/8"          | 3/8"         | 1-1/2"          | 1/8"           | SG-43 |
| CB-SG1   | 1/4"          | 5/8"         | 2"              | 1/4"           | SG-1  |
| CB-SG2   | 5/16"         | 3/4"         | 2-1/2"          | 1/4"           | SG-2  |
| CB-SG3   | 3/8"          | 3/4"         | 2-1/2"          | 1/4"           | SG-3  |
| CB-SG5   | 1/2"          | 1"           | 2-3/4"          | 1/4"           | SG-5  |
| CB-SG6   | 5/8"          | 1"           | 2-3/4"          | 1/4"           | SG-6  |
| CB-SG7   | 3/4"          | 1"           | 2-3/4"          | 1/4"           | SG-7  |

## CONE SHAPE



| Part No. | Head Diameter | Flute Length | Over All Length | Shank Diameter | Angle | Style |
|----------|---------------|--------------|-----------------|----------------|-------|-------|
| CB-SM42  | 1/8"          | 1/2"         | 1-1/2"          | 1/8"           | 12°   | SM-42 |
| CB-SM2   | 1/4"          | 3/4"         | 2"              | 1/4"           | 14°   | SM-2  |
| CB-SM4   | 3/8"          | 3/4"         | 2-1/2"          | 1/4"           | 28°   | SM-4  |
| CB-SM5   | 1/2"          | 1"           | 2-3/4"          | 1/4"           | 28°   | SM-5  |
| CB-SM6   | 5/8"          | 1-1/8"       | 2-7/8"          | 1/4"           | 31°   | SM-6  |

## FLAME SHAPE



| Part No. | Head Diameter | Flute Length | Over All Length | Shank Diameter | Style |
|----------|---------------|--------------|-----------------|----------------|-------|
| CB-SH41  | 1/8"          | 1/4"         | 1-1/2"          | 1/8"           | SH-41 |
| CB-SH1   | 1/4"          | 5/8"         | 2"              | 1/4"           | SH-1  |
| CB-SH2   | 5/16"         | 3/4"         | 2-1/2"          | 1/4"           | SH-2  |
| CB-SH3   | 3/8"          | 1"           | 2-3/4"          | 1/4"           | SH-3  |
| CB-SH5   | 1/2"          | 1-1/4"       | 3"              | 1/4"           | SH-5  |
| CB-SH6   | 5/8"          | 1-7/16"      | 3-3/16"         | 1/4"           | SH-6  |
| CB-SH7   | 3/4"          | 1-5/8"       | 3-3/8"          | 1/4"           | SH-7  |

## INVERTED CONE SHAPE



| Part No. | Head Diameter | Flute Length | Over All Length | Shank Diameter | Angle | Style |
|----------|---------------|--------------|-----------------|----------------|-------|-------|
| CB-SN42  | 1/8"          | 1/8"         | 1-1/2"          | 1/8"           | 14°   | SN-42 |
| CB-SN1   | 1/4"          | 1/4"         | 2"              | 1/4"           | 10°   | SN-1  |
| CB-SN2   | 3/8"          | 3/8"         | 2-1/8"          | 1/4"           | 13°   | SN-2  |
| CB-SN4   | 1/2"          | 1/2"         | 2-1/4"          | 1/4"           | 28°   | SN-4  |
| CB-SN6   | 5/8"          | 3/4"         | 2-1/2"          | 1/4"           | 18°   | SN-6  |
| CB-SN7   | 3/4"          | 5/8"         | 2-3/8"          | 1/4"           | 30°   | SN-7  |

## CARBIDE BURRS

### EXTENDED SHANK DOUBLE CUT

#### CYLINDRICAL - END CUT



| Part No. | Head Diameter | Flute Length | Over All Length | Shank Diameter | Style  |
|----------|---------------|--------------|-----------------|----------------|--------|
| CB-SB1L6 | 1/4"          | 5/8"         | 6-5/8"          | 1/4"           | SB-1L6 |
| CB-SB3L6 | 3/8"          | 3/4"         | 6-3/4"          | 1/4"           | SB-3L6 |
| CB-SB5L6 | 1/2"          | 1"           | 7"              | 1/4"           | SB-5L6 |

#### CYLINDRICAL - RADIUS END



| Part No. | Head Diameter | Flute Length | Over All Length | Shank Diameter | Style  |
|----------|---------------|--------------|-----------------|----------------|--------|
| CB-SC1L6 | 1/4"          | 5/8"         | 6-5/8"          | 1/4"           | SC-1L6 |
| CB-SC3L6 | 3/8"          | 3/4"         | 6-3/4"          | 1/4"           | SC-3L6 |
| CB-SC5L6 | 1/2"          | 1"           | 7"              | 1/4"           | SC-5L6 |

#### BALL SHAPE



| Part No. | Head Diameter | Flute Length | Over All Length | Shank Diameter | Style  |
|----------|---------------|--------------|-----------------|----------------|--------|
| CB-SD1L6 | 1/4"          | -            | 6-1/8"          | 1/4"           | SD-1L6 |
| CB-SD3L6 | 3/8"          | -            | 6-1/4"          | 1/4"           | SD-3L6 |
| CB-SD5L6 | 1/2"          | -            | 6-3/8"          | 1/4"           | SD-5L6 |

#### TREE SHAPE - RADIUS END



| Part No. | Head Diameter | Flute Length | Over All Length | Shank Diameter | Style  |
|----------|---------------|--------------|-----------------|----------------|--------|
| CB-SF1L6 | 1/4"          | 5/8"         | 6-5/8"          | 1/4"           | SF-1L6 |
| CB-SF3L6 | 3/8"          | 3/4"         | 6-3/4"          | 1/4"           | SF-3L6 |
| CB-SF5L6 | 1/2"          | 1"           | 7"              | 1/4"           | SF-5L6 |

#### TAPERED - RADIUS END

14° Included Angle



| Part No. | Head Diameter | Flute Length | Over All Length | Shank Diameter | Style  |
|----------|---------------|--------------|-----------------|----------------|--------|
| CB-SL1L6 | 1/4"          | 5/8"         | 6-5/8"          | 1/4"           | SL-1L6 |
| CB-SL3L6 | 3/8"          | 1-1/16"      | 7"              | 1/4"           | SL-3L6 |
| CB-SL4L6 | 1/2"          | 1-1/8"       | 7-1/8"          | 1/4"           | SL-4L6 |

## CARBIDE BURRS ALUMINIUM CUT

### CYLINDRICAL - SQUARE END



| Part No.  | Head Diameter | Flute Length | Over All Length | Shank Diameter | Style  |
|-----------|---------------|--------------|-----------------|----------------|--------|
| CB-SA1-AC | 1/4"          | 3/4"         | 2"              | 1/4"           | SA-1AC |
| CB-SA3-AC | 3/8"          | 3/4"         | 2-1/2"          | 1/4"           | SA-3AC |
| CB-SA5-AC | 1/2"          | 1"           | 2-3/4"          | 1/4"           | SA-5AC |
| CB-SA6-AC | 5/8"          | 1"           | 2-3/4"          | 1/4"           | SA-6AC |
| CB-SA7-AC | 3/4"          | 1"           | 2-3/4"          | 1/4"           | SA-7AC |

### CYLINDRICAL - RADIUS END



| Part No.  | Head Diameter | Flute Length | Over All Length | Shank Diameter | Style  |
|-----------|---------------|--------------|-----------------|----------------|--------|
| CB-SC1-AC | 1/4"          | 5/8"         | 2"              | 1/4"           | SC-1AC |
| CB-SC3-AC | 3/8"          | 3/4"         | 2-1/2"          | 1/4"           | SC-3AC |
| CB-SC5-AC | 1/2"          | 1"           | 2-3/4"          | 1/4"           | SC-5AC |
| CB-SC6-AC | 5/8"          | 1"           | 2-3/4"          | 1/4"           | SC-6AC |
| CB-SC7-AC | 3/4"          | 1"           | 2-3/4"          | 1/4"           | SC-7AC |

### BALL SHAPE



| Part No.  | Head Diameter | Flute Length | Over All Length | Shank Diameter | Style  |
|-----------|---------------|--------------|-----------------|----------------|--------|
| CB-SD1-AC | 1/4"          | -            | 2"              | 1/4"           | SD-1AC |
| CB-SD3-AC | 3/8"          | -            | 2-1/16"         | 1/4"           | SD-3AC |
| CB-SD5-AC | 1/2"          | -            | 2-3/16"         | 1/4"           | SD-5AC |
| CB-SD6-AC | 5/8"          | -            | 2-5/16"         | 1/4"           | SD-6AC |
| CB-SD7-AC | 3/4"          | -            | 2-7/16"         | 1/4"           | SD-7AC |

### OVAL SHAPE



| Part No.  | Head Diameter | Flute Length | Over All Length | Shank Diameter | Style  |
|-----------|---------------|--------------|-----------------|----------------|--------|
| CB-SE1-AC | 1/4"          | 3/8"         | 2"              | 1/4"           | SE-1AC |
| CB-SE3-AC | 3/8"          | 5/8"         | 2-3/8"          | 1/4"           | SE-3AC |
| CB-SE5-AC | 1/2"          | 7/8"         | 2-5/8"          | 1/4"           | SE-5AC |
| CB-SE6-AC | 5/8"          | 1"           | 2-3/4"          | 1/4"           | SE-6AC |

### TREE SHAPE - RADIUS END



| Part No.  | Head Diameter | Flute Length | Over All Length | Shank Diameter | Style  |
|-----------|---------------|--------------|-----------------|----------------|--------|
| CB-SF1-AC | 1/4"          | 3/4"         | 2"              | 1/4"           | SF-1AC |
| CB-SF3-AC | 3/8"          | 3/4"         | 2-1/2"          | 1/4"           | SF-3AC |
| CB-SF5-AC | 1/2"          | 1"           | 2-3/4"          | 1/4"           | SF-5AC |
| CB-SF6-AC | 5/8"          | 1"           | 2-3/4"          | 1/4"           | SF-6AC |

### TAPERED - RADIUS END

14° Included Angle



| Part No.  | Head Diameter | Flute Length | Over All Length | Shank Diameter | Style  |
|-----------|---------------|--------------|-----------------|----------------|--------|
| CB-SL3-AC | 3/8"          | 1-1/16"      | 2-13/16"        | 1/4"           | SL-3AC |
| CB-SL4-AC | 1/2"          | 1-1/8"       | 2-7/8"          | 1/4"           | SL-4AC |
| CB-SL6-AC | 5/8"          | 1-5/16"      | 3-1/16"         | 1/4"           | SL-6AC |
| CB-SL7-AC | 3/4"          | 1-1/2"       | 3-1/4"          | 1/4"           | SL-7AC |